

General Description

The GGM-5853F5LW-AGGB4P500 is a receiving Gmouse that supports dual frequency and multi-mode. It has built-in highly integrated GNSS receiver chip, supports multi band and multi system cm4f (main frequency 530mhz,12NM Technology) chip of Third-generation BeiDou Navigation Satellite System (BDS-3). Besides, it is capable of tracking allglobal civil navigation systems (BDS, GPS, GLONASS, Galileo, QZSS and SBAS) in all bands.

GGM-5853F5LW-AGGB4P500 Gmouse is based on the state of art CYNOSURE III architecture, integrating multi-band and multi-system GNSS RF and baseband.This newly designed architecture makes this single chip achieve sub-meter level position accuracy without correction data from ground-based augmentation station and higher sensitivity, greater for improved jam resistance and multipath, provide a highly robust service in complicated environment.

GGM-5853F5LW-AGGB4P500 Gmouse contains AG 3335 positioning engine inside, featuring high sensitivity, low power consumption, and fast TTFF. The superior cold start sensitivity allows it to acquire, track, and get position fix autonomously in difficult weak signal environment. The receiver's superior tracking sensitivity allows continuous position coverage in nearly all outdoor application environments. The high performance signal parameter search engine is capable of testing 16 million time-frequency hypotheses per second, offering superior signal acquisition and TTFF speed.

Applications

- LBS (Location Based Service)
- PND (Portable Navigation Device)
- Vehicle navigation system
- Mobile phone



**Figure: GGM-5853F5LW-AGGB4P500
Top View**

Features

- Build on high performance, low-power MediaTek AG3335 chip set
- Ultra high Track sensitivity: -165dBm
- Concurrent reception of multi-band and multi-system satellite signals
- Supports all civil GNSS signals
- Supports BDS-3 signal
- Extremely fast TTFF at low signal level (Cold start $\leq 24s$, Hot start $\leq 1s$).
- Multipath detection and suppression
- Works with passive and active antenna
- Operating voltage:3.0V~5.5V
- Low power consumption: Max 28 \pm 2mA@5.0V
- NMEA-0183 compliant protocol or custom protocol
- Operating temperature -40~+85°C
- Patch Antenna Size:35x35x4mm&25x25x4mm
- Small form factor: 52.7 \pm 0.5x57.6 \pm 0.5x20.72 \pm 0.5mm
- Communication type: UART
- Wire interface type: Molex 4Pin, L=500 \pm 5cm
- Waterproofing grade: IP67
- RoHS compliant (Lead-free)

1. Functional Description

1.1. Key Features

Parameter	Specification
GNSS engine	<ul style="list-style-type: none"> GNSS engine has 135 channels and DSP accelerators
GNSS reception	<ul style="list-style-type: none"> GPS/QZSS: L1 C/A, L5 GLONASS: L1OF GALILEO: E1(E1B+E1C), E5A BEIDOU: B1I, B2A SBAS: WAAS, EGNOS, MSAS, GAGAN
Update rate	<ul style="list-style-type: none"> GNSS 20Hz Maximum
Position accuracy ^[1]	<ul style="list-style-type: none"> GNSS <1m CEP SBAS <1m CEP D-GNSS <2.5cm CEP
Velocity & Time accuracy	<ul style="list-style-type: none"> GNSS 0.01m/s CEP SBAS 0.05 m/s D-GNSS 0.05 m/s 1PPS 25 ns
Time to First Fix(TTFF) ^[1]	<ul style="list-style-type: none"> Hot start 1 sec Cold start 24 secs
1PPS accuracy	<ul style="list-style-type: none"> When using four or more satellites for 3D positioning, the rising edge of the pulse generating 1 pulse per second (Duration: 800 seconds) on 1PPS pins is aligned with the UTC seconds, and the accuracy is about 20nS. When it is not positioned, it outputs a constant low pulse.
Sensitivity ^[1]	<ul style="list-style-type: none"> Cold start -148dBm Hot start -155dBm Reacquisition -158dBm Tracking & navigation -165dBm
GNSS Operating limit	<ul style="list-style-type: none"> Velocity 515m/s Altitude 18,000m
Datum	<ul style="list-style-type: none"> Default WGS-84, or be customized
USB Port	<ul style="list-style-type: none"> UART Port: TXD and RXD Supports baud rate from 9600bps to 961200bps. NMEA 0183 Protocol Ver. 4.00/4.10, Cynosure GNSS Receiver Protocol
Temperature Range	<ul style="list-style-type: none"> Normal operation: -40°C ~ +85°C Storage temperature: -55°C ~ +100°C Humidity: 5% ~ 95%
Physical Characteristics	<ul style="list-style-type: none"> Size: 52.7±0.5x57.6±0.5x20.72±0.5mm Weight: Approx. 150g

1.2 Block Diagram

The GGM-5853F5LW-AGGB4P500 is a high performance (BDS, GPS, GLONASS, Galileo, QZSS and SBAS) in all bands (L1, L5). satellite navigation receiver in a compact surface mount package. It is based on the AG3335 positioning technology, providing high performance signal acquisition and tracking. The simple USB serial interface and the standard NMEA-0183 protocol make usage of GGM-5853F5LW-AGGB4P500 very easy and straightforward.

The GGM-5853F5LW-AGGB4P500 Gmouse performs all the necessary system initialization, signal acquisition, signal tracking, data demodulation, and calculation of navigation solution autonomously.

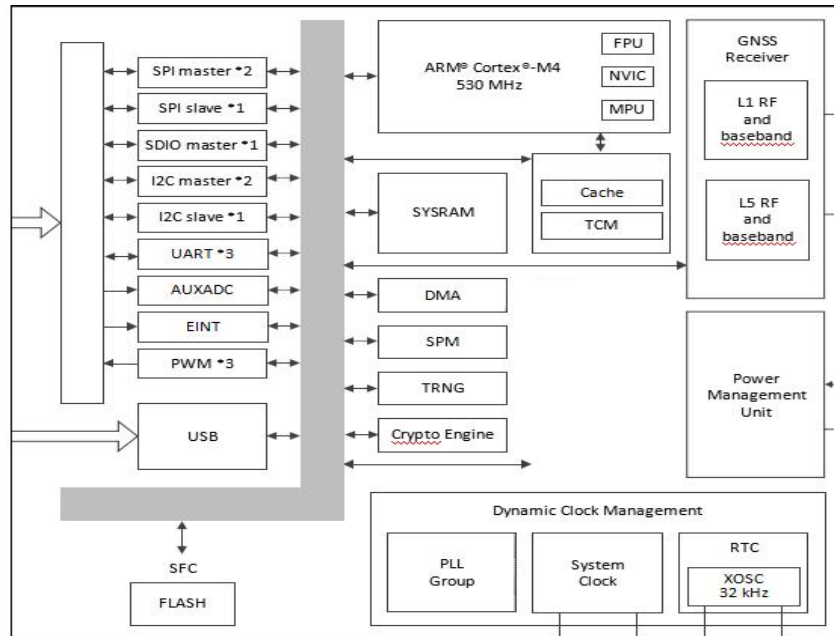
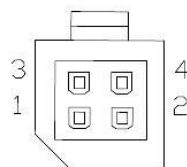

Figure 1: Block Diagram

2. Application and Mechanical Dimensions

GGM-5853F5LW-AGGB4P500 Gmouse is equipped with a 4-pin USB connector that connects to your application platform. It consists of a MediaTek AG3335 GNSS IC which includes the RF part and Baseband part, a patch antenna, a LNA, a SAW filter, a TCXO, a crystal oscillator, Also comes with a 0.22F crystal capacitor ,can backup satellite ephemeris about 2 hour.

2.1 Pin Assignment



4PIN Molex connector

Figure 2: Pin Assignment

CON Pin Description

Pin No.	Pin name	I/O	Description	Remark
1	RX	I	UART Serial Data input	Voltage range: 3.0V~5.5V
2	GND	G	Ground	
3	TX	O	UART Serial Data Output	
4	VCC	I	Module Power Supply	

2.2 Mechanical Dimensions

This chapter describes the mechanical dimensions of the GGM-5853F5LW-AGGB4P500 Gmouse. Size unit (mm)

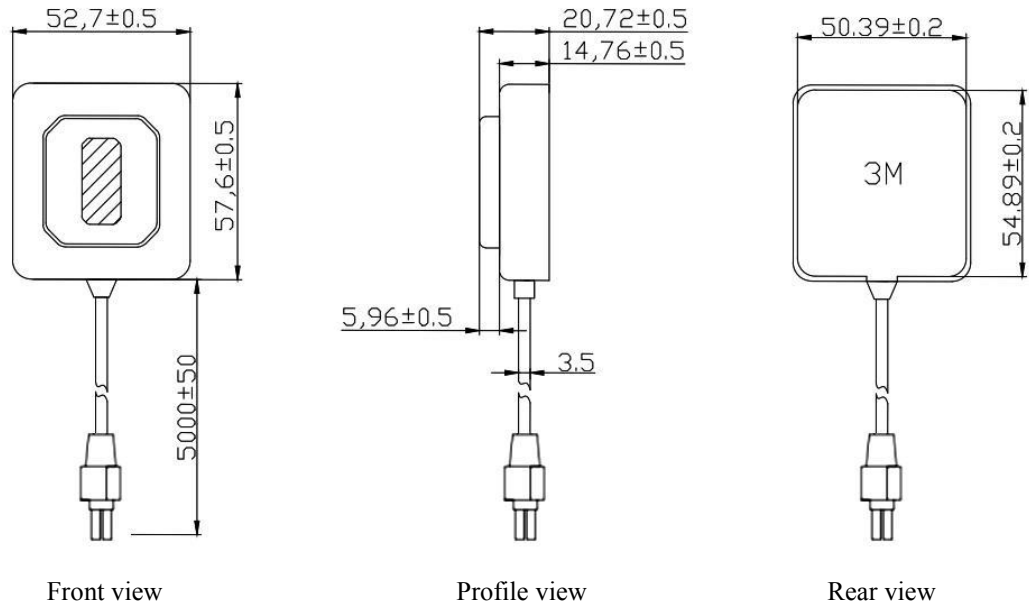

Figure 3: Specification size chart

2.3 Electrical Specification

Absolute Maximum Ratings

Parameter	Minimum	Maximum	Condition
Supply Voltage (VCC)	-0.5	5.5	Volt
Input Pin Voltage	-0.5	VCC+0.5	Volt
Input Power at RF_IN		+20	dBm
Storage Temperature	-55	+100	degC

Operating Conditions

Parameter	Min	Typ	Max	Unit
Supply Voltage (VCC)	3	5.0	5.5	Volt
Acquisition Current (exclude active antenna current)		28		mA
Tracking Current (exclude active antenna current)		25		mA
I/O port & USB port working voltage				
Output Low Voltage	1.2		0.4	Volt
Output HIGH Voltage	3.3			Volt
Input LOW Voltage	1.2		0.8	Volt
Input HIGH Voltage	3.3			Volt
Input LOW Current	-10		10	uA
Input HIGH Current	-10		10	uA

3. NMEA 0183 Protocol

The output protocol supports NMEA-0183 standard. The implemented messages include GGA, GLL, GSA, GSV, VTG, RMC, and ZDA messages. The NMEA message output has the following sentence structure: \$AACCC , c-c*hh

3.1 The detail of the sentence structure is explained in Table 1.

Table 1: The NMEA sentence structure

character	HEX	Description
“\$”	24	Start of sentence.
Aaccc		Address field. “aa” is the talker identifier. “ccc” identifies the sentence type.
“,”	2C	Field delimiter.
C–c		Data sentence block.
“*”	2A	Checksum delimiter.
Hh		Checksum field.
<CR><LF>	0D0A	Ending of sentence. (carriage return, line feed)

Table 2: Overview of NMEA messages

\$GNGGA	Time, position, and fix related data of the receiver.
\$GNGLL	Position, time and fix status.
\$GNGSA	Used to represent the ID of satellites which are used for position fix. When GPS&GLONASS&Galileo & BDS satellites are used for positioning solutions, the ID of available positioning satellites is counted and output with multiple statements.
\$GPGSV \$GLGSV \$GAGSV \$GBGSV	Satellite information about elevation, azimuth and CNR, satellites are used in position solution, a \$GPGSV sentence is used for GPS satellites, a \$GLGSV sentence is used for GLONASS satellites, a \$GAGSV sentence is used for GALILEO satellites. And \$BDGSV sentence is used for BDS satellites.

\$GNRMC	Time, date, position, course and speed data.
\$GNVTG	Course and speed relative to the ground.
\$GNZDA	UTC, day, month and year and time zone.

- ✧ The GGM-5853F5L-AGGBL200 Initialization location mode for GPS&Beidou&Glonass&Galileo four-mode.
Output data: \$GNRMC,\$GNVTG,\$GNZDA,\$GNNGA,\$GNGLL,\$GNNSA,\$GPGSV,\$GLGSV,\$GAGSV,\$GBGSV

3.2 The formats of the supported NMEA messages are described as follows:

3.2.1 GGA – Global Positioning System Fix Data

Time, position and fix related data for a GNSS receiver.

Structure:\$GNNGA,hhmmss.sss,ddmm.mmmm,a,dddmm.mmmm,a,x,xx,x.x,x.x,M,x.x,M,x.x,xxxx*hh

For example:

\$GNNGA,175258.000,2447.0870,N,12100.5221,E,2,15,0.7,95.2,M,19.6,M,,0000*72

Field	Name	Example	Description
1	UTC Time	175258.000	UTC of position in hhmmss.sss format, (000000.000 ~ 235959.999)
2	Latitude	2447.08700	Latitude in ddmm.mmmmm format Leading zeros transmitted
3	N/S Indicator	N	Latitude hemisphere indicator, 'N' = North, 'S' = South
4	Longitude	12100.52210	Longitude in dddmm.mmmmm format Leading zeros transmitted
5	E/W Indicator	E	Longitude hemisphere indicator, 'E' = East, 'W' = West
6	Quality Indicator	2	Quality Indicator 0: position fix unavailable 1: valid position fix, SPS mode 2: valid position fix, differential GPS mode 3: GPS PPS Mode, fix valid 6: Estimated (dead reckoning) Mode
7	Satellites Used	15	Number of satellites in use, (00 ~ 56)
8	HDOP	0.7	Horizontal dilution of precision, (0.0 ~ 99.9)
9	Altitude	95.2	mean sea level (geoid), (- 9999.9 ~ 17999.9)
10	Geoidal Separation	19.6	Geoidal separation in meters
11	Age of Differential GPS data		Age of Differential GPS data NULL when DGPS not used
12	DGPS Station ID	0000	Differential reference station ID, 0000 ~ 1023
13	Checksum	72	

3.2.2 GLL – Latitude/Longitude

Latitude and longitude of current position, time, and status.

Structure:\$GNGLL,ddmm.mmmm,a,dddmm.mmmm,a,hhmmss.sss,A,a*hh

For example:

\$GNGLL,2447.0870,N,12100.5221,E,175258.000,A,D*42

Field	Name	Example	Description
1	Latitude	2447.08700	Latitude in ddmm.mmmmm format Leading zeros transmitted

2	N/S Indicator	N	Latitude hemisphere indicator 'N' = North 'S' = South
3	Longitude	12100.52210	Longitude in dddmm.mmmmm format Leading zeros transmitted
4	E/W Indicator	E	Longitude hemisphere indicator 'E' = East 'W' = West
5	UTC Time	175258.000	UTC time in hhmmss.sss format (000000.000 ~ 235959.999)
6	Status	A	Status, 'A' = Data valid, 'V' = Data not valid
7	Mode Indicator	D	Mode indicator 'N' = Data not valid 'A' = Autonomous mode 'D' = Differential mode 'E' = Estimated (dead reckoning) mode
8	Checksum	42	

3.2.3 GSA – GNSS DOP and Active Satellites

GNSS receiver operating mode, satellites used in the navigation solution reported by the GGA sentence and DOP values.

Structure: \$GNGSA,A,x,xx,xx,xx,xx,xx,xx,xx,xx,xx,xx,xx,x.x,x.x,x.x,x*hh

For example:

\$GNGSA,A,3,21,12,15,18,20,24,10,32,25,13,,,1.2,0.7,1.0,1*18

\$GNGSA,A,3,03,04,05,07,,,,,,,,,1.2,0.7,1.0,4*34

\$GNGSA,A,3,76,86,71,72,65,85,87,77,,,,,1.0,0.5,0.9,2*32

\$GNGSA,A,3,76,44,13,15,66,23,45,28,,,,,1.0,0.5,0.9,2*32

Field	Name	Example	Description
1	Mode	A	Mode 'M' = Manual, forced to operate in 2D or 3D mode 'A' = Automatic, allowed to automatically switch 2D/3D
2	Mode	3	Fix type 1 = Fix not available 2 = 2D 3 = 3D
3	Satellite used 1~12	21, 12, 15, 18, 20, 24, 10, 32, 25, 13	01 ~ 32 are for GPS; 33 ~ 64 are for WAAS (PRN minus 87); 193 ~ 197 are for QZSS; 65 ~ 88 are for GLONASS (GL PRN); 01 ~ 36 are for GALILEO (GA PRN); 01 ~ 37 are for BDS (BD PRN). GPS, GLONASS, GALILEO and BDS satellites are differentiated by the GNSS system ID in table 3. Maximally 12 satellites are included in each GSA sentence
4	PDOP	1.2	Position dilution of precision (0.0 to 99.9)
5	HDOP	0.7	Horizontal dilution of precision (0.0 to 99.9)
6	VDOP	1.0	Vertical dilution of precision (0.0 to 99.9)
7	GNSS System ID	1	1 for GPS, 2 for GLONASS, 3 for GALILEO, 4 for BDS
8	Checksum	18	

3.2.4 GSV – GNSS Satellites in View

Number of satellites (SV) in view, satellite ID numbers, elevation, azimuth, and SNR value. Four satellites maximum per transmission.

Structure: \$GPGSV , x , x , xx , xx , xx , xx , xx , ... , xx , xx , xx , xx , xx , x*hh

For example :

\$GPGSV , 4,1 , 13 , 02,72 , 109 , 43,24 , 69,035 , 48,18 , 52,330 , 42,21 , 49,246 , 43 , 1*69

\$GPGSV , 4,2 , 13 , 20,47 , 118 , 42,15 , 39,046 , 44,41 , 39,242 , 41,12 , 28,129 , 42 , 1*68

\$GBGSV , 4,3 , 13 , 10,25 , 321 , 38,25 , 15,170 , 35,32 , 14,278 , 36,136 , 063 , 35 , 1*64

\$GBGSV , 4,4 , 13 , 05,04 , 126 , 36 , 1*57

\$GBGSV , 2,1 , 07 , 67,63 , 158 , 46,05 , 61,202 , 44,04 , 57,199 , 44,03 , 39,243 , 42,4*7f

\$GAGSV , 2,2 , 07 , 01 , 00,000 , 39,02 , 00,000 , 24,06 , 00,266 , 4*44

\$GAGSV , 3,1 , 09 , 72,60 , 135,48 , 71,40 , 047 , 50,86 , 37,048 , 50,87 , 30,336 , 49 , 1*7b

\$GLGSV , 3,2 , 09 , 65,24 , 184,477 , 23,278 , 43,76 , 16,218 , 44,85 , 05,095 , 40 , 1*7e

\$GLGSV , 3,3 , 09 , 78,00 , 000 , 31,1*4c

Field	Name	Example	Description
1	Number of message	4	Total number of GSV messages to be transmitted (1 - 5)
2	Sequence number	1	Sequence number of current GSV message
3	Satellites in view	13	Total number of satellites in view (00 ~ 20)
4	Satellite ID	02	01 ~ 32 are for GPS; 33 ~ 64 are for WAAS (PRN minus 87); 193 ~ 197 are for QZSS; 65 ~ 88 are for GLONASS (GL PRN) ; 01 ~ 36 are for GALILEO (GA PRN); 01 ~ 37 are for BDS (BD PRN). GPS, GLONASS, GALILEO and BDS satellites are differentiated by the GNSS system ID in table 3. Maximally 12 satellites are included in each GSA sentence
5	Elevation	72	Satellite elevation in degrees, (00 ~ 90)
6	Azimuth	109	Satellite azimuth angle in degrees, (000 ~ 359)
7	SNR	43	C/No in dB (00 ~ 99) Null when not tracking
8	Signal ID	1	1 for L1/CA, 4 for L5/CA
9	Checksum	69	

3.2.5 RMC – Recommended Minimum Specific GNSS Data

Time, date, position, course and speed data provided by a GNSS navigation receiver.

Structure: \$GNRMC,hhmmss.sss,A,dddmm.mmmm,a,dddmm.mmmm,a,x.x,x.x,ddmmyy,,a*hh

For example:

\$GNRMC,175258.000,A,2447.0870,N,12100.5220,E,000.0,000.0,220617,,D*75

Field	Name	Example	Description
1	UTC time	175258.000	UTC time in hhmmss.sss format (000000.00 ~ 235959.999)
2	Status	A	Status 'V' = Navigation receiver warning 'A' = Data Valid
3	Latitude	2447.08700	Latitude in dddmm.mmmmm format Leading zeros transmitted
4	N/S indicator	N	Latitude hemisphere indicator 'N' =North 'S' = South

5	Longitude	12100.52210	Longitude in dddmm.mmmmm format Leading zeros transmitted
6	E/W Indicator	E	Longitude hemisphere indicator 'E' = East 'W' = West
7	Speed over ground	000.0	Speed over ground in knots (000.0 ~ 999.9)
8	Course over ground	000.0	Course over ground in degrees (000.0 ~ 359.9)
9	UTC Date	220617	UTC date of position fix, ddmmyy format
10	Mode indicator	D	Mode indicator 'N' = Data not valid 'A' = Autonomous mode 'D' = Differential mode 'E' = Estimated (dead reckoning) mode
11	checksum	75	

3.2.6 VTG – Course Over Ground and Ground Speed

The actual course and speed relative to the ground.

Structure: GNVTG,x.x,T,,M,x.x,N,x.x,K,a*hh

For example:

\$GNVTG,000.0,T,,M,000.0,N,000.0,K,D*16

Field	Name	Example	Description
1	Course	000.0	True course over ground in degrees (000.0 ~ 359.9)
2	Speed	000.0	Speed over ground in knots (000.0 ~ 999.9)
3	Speed	000.0	Speed over ground in kilometers per hour (000.0 ~ 1800.0)
4	Mode	D	Mode indicator 'N' = Data not valid 'A' = Autonomous mode 'D' = Differential mode 'E' = Estimated (dead reckoning) mode
5	Checksum	16	

3.2.7 ZDA – Time and Data

UTC, day, month, year and local time zone

Structure: \$GNZDA,hhmmss.sss,xx,xx,xxxx,xx,xx*hh<CR><LF>

For example:

\$GNZDA,175258.000,22,06,2017,00,00*46<CR><LF>

Field	Name	Example	Units	Description
1	UTC time	175258.000		UTC time in hhmmss.ss format (000000.00 ~ 235959.99)
2	UTC Day	22		UTC time: day (01 ~ 31)
3	UTC Month	06		UTC time: month (01 ~ 12)
4	UTC Year	2017		UTC time: year (4 digit format)
5	Local zone hour	00		Local zone hours (00 ~ +/- 13)
6	Local zone minutes	00		Local zone minutes (00 ~59)
7	Checksum	46		Checksum

©Copyright 2022 Gotop Technology Co., Ltd. All Right Reserved
The information contained herein is subject to change without notice.
Gotop Technology Co. , LTD

Add:AreaC,4th layer,A1 building,QingHu Silicon Valley Power,LongHua district ,Shenzhen ,China
Phone: 86-755-23804156
fax: 86-755-23804155
N 22° 32' 17", E 114° 07' 07"
<http://www.gotop-zzu.com>

Not to be reproduced in whole or part for any purpose without written permission of Gotop Technology Inc ('Gotop'). Information provided by Gotop is believed to be accurate and reliable. These materials are provided by Gotop as a service to its customers and may be used for informational purposes only. Gotop assumes no responsibility for errors or omissions in these materials, nor for its use. Gotop reserves the right to change specification at any time without notice.

These materials are provided 'as is' without warranty of any kind, either expressed or implied, relating to sale and/or use of Gotop products including liability or warranties relating to fitness for a particular purpose, consequential or incidental damages, merchantability, or infringement of any patent, copyright or other intellectual property right. Gotop further does not warrant the accuracy or completeness of the information, text, graphics or other items contained within these materials. Gotop shall not be liable for any special, indirect, incidental, or consequential damages, including without limitation, lost revenues or lost profits, which may result from the use of these materials.

Gotop products are not intended for use in medical, life-support devices, or applications involving potential risk of death, personal injury, or severe property damage in case of failure of the product.