

General Description

The Gotop GT-1110U-GKBD is a complete GPS&Beidou engine module that features super sensitivity, ultra low power and small form factor. The GPS&Beidou signal is applied to the antenna input of module, and a complete serial data message with position, velocity and time information is presented at the serial interface with NMEA protocol or custom protocol.

Its -165dBm tracking sensitivity extends positioning coverage into place like urban canyons and dense foliage environment where the GPS&Beidou was not possible before. The small form factor and low power consumption make the module easy to integrate into portable device like PNDs, mobile phones, cameras and vehicle navigation systems.

Applications

- LBS (Location Based Service)
- PND (Portable Navigation Device)
- Vehicle navigation system
- Mobile phone



Figure: GT-1110U-GKBD Top View

Features

- Build on high performance, low-power GK9501-QFN chip set
- Ultra high Track sensitivity: -165dBm
- Built in high gain LNA
- Low power consumption: Max 40mA@3.3V
- NMEA-0183 compliant protocol or custom protocol
- Operating voltage: 2.8V to 4.3V
- Operating temperature range:-40to85°C
- SMD type with stamp holes
- Small form factor: 11x10x2.2mm
- RoHS compliant (Lead-free)

1 .Description	3
1.1. Key Features.....	3
1.2. Block Diagram.....	4
2 Application	4
2.1. Pin Assignment.....	5
2.2. Pin Definition.....	5
2.3. Power Supply.....	6
2.4. UART Interface.....	9
2.5. PPS VS. NMEA.....	10
3 Antenna Interfaces	11
3.1. PCB Design Guide.....	11
3.2. External Active Antenna.....	11
4 Electrical, Reliability and Radio Characteristics	12
4.1. Absolute Maximum Ratings.....	12
4.2. Operating Conditions.....	13
4.3. Current Consumption.....	13
4.4. Electrostatic Discharge.....	14
4.5. Reliability Test.....	14
5 Mechanical Dimensions	15
6 Manufacturing, Packaging and Ordering Information	15
6.1. Assembly and Soldering.....	15
6.2. Moisture Sensitivity.....	16
6.3. ESD Protection.....	16
6.4. Tape and Reel Packaging.....	16
7 Appendix References	18
8 Configuration instruction Explain	20
9 NMEA 0183 Protocol	20
9.1 GGA-Global Positioning System Fixed Data.....	21
9.2 GLL-Geographic Position – Latitude/Longitude.....	22
9.3 GSA-GPS DOP and Active Satellites.....	22
9.4 GSV-GPS Satellites in View.....	23
9.5 RMC-Recommended Minimum Specific GPS Data.....	23
9.6 VTG-Course Over Ground and Ground Speed.....	24

1.1. Key Features

Table 1: Key Features

Parameter	Specification
Power Supply	<ul style="list-style-type: none"> Supply voltage: 2.8V~4.3V Typical: 3.3V
Power Consumption	<ul style="list-style-type: none"> Acquisition: 40mA @VCC=V_BCKP=3.3V Tracking: 35mA @VCC=V_BCKP=3.3V Standby: 2.0mA @VCC=V_BCKP=3.3V Backup: 15uA @V_BCKP=3.3V
Receiver Type	<ul style="list-style-type: none"> Code 66 search channels, 22 synchronous tracking channels GPS&QZSS L1 1575.42MHz C/A SBAS: WAAS, EGNOS, MSAS, GAGAN
Sensitivity	<ul style="list-style-type: none"> Tracking: -165dBm Re-acquisition: -164dBm Acquisition: -130dBm
TTF (Autonomous)	<ul style="list-style-type: none"> Cold start : 35s typ @-130dBm Warm start : 30s typ @-130dBm Hot start : 1s typ @-162dBm
Horizontal Position Accuracy (Autonomous)	<ul style="list-style-type: none"> <2.5m CEP @-130dBm
Max Update Rate	<ul style="list-style-type: none"> Up to 10Hz,1Hz by fault
Accuracy of 1PPS Signal	<ul style="list-style-type: none"> Typical accuracy: ± 10ns Time pulse width 100ms
Acceleration Accuracy	<ul style="list-style-type: none"> Without aid: 0.1m/s^2
Dynamic Performance	<ul style="list-style-type: none"> Maximum altitude: 18,000m Maximum velocity: 515m/s Acceleration: 4G
UART Port	<ul style="list-style-type: none"> UART Port: TXD and RXD Supports baud rate from 4800bps to 115200bps, 9600bps by default UART port is used for NMEA output, GK proprietary commands input and firmware upgrade
Temperature Range	<ul style="list-style-type: none"> Normal operation: $-40^{\circ}\text{C} \sim +85^{\circ}\text{C}$ Storage temperature: $-45^{\circ}\text{C} \sim +125^{\circ}\text{C}$
Physical Characteristics	<ul style="list-style-type: none"> Size: $10.1\pm 0.15 \times 9.7\pm 0.15 \times 2.2\pm 0.15\text{mm}$ Weight: Approx. 0.41g

1.2. Block Diagram

The following figure shows a block diagram of GT-1110U-GKBD module. It consists of a single chip GPS IC which includes the RF part and Baseband part, a LNA, a SAW filter, a TCXO, a crystal oscillator.

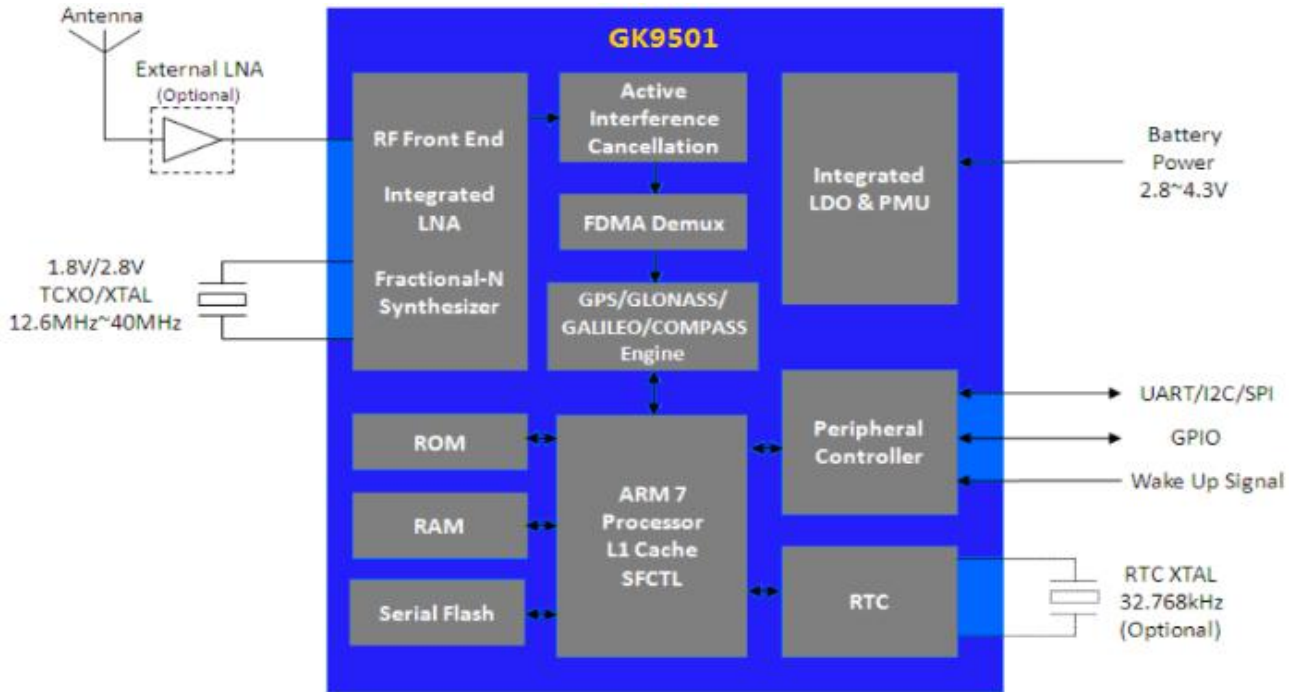

Figure 1: Block Diagram

2 Application

The module is equipped with a 18-pin SMT pad that connects to your application platform. Sub-interfaces included in the pad are described in details in the following chapters.

2.1. Pin Assignment



Figure 2: Pin Assignment

2.2. Pin Definition

Power Supply					
Pin Name	Pin No.	I/O	Description	DC Characteristics	Comment
VCC_3.3V	8	I	Main power supply	V _{max} =4.3V V _{min} =2.8V V _{nom} =3.3V	Supply current not less than 100mA.
VBAT	6	I	RTC Battery Input	V _{max} =4.3V V _{min} =1.5V V _{nom} =3.3V	Supply power for RTC domain. The VBAT pin can be directly supplied power by battery or connect it to VCC.
GND	1.10.12	G	Ground.		Assure a good GND connection to all GND pins of the module, preferably with a large ground plane.
Reset					
Pin Name	Pin No.	I/O	Description	DC Characteristics	Comment
RESET_N	9	I	System reset	V _{ILmin} =-0.3V V _{ILmax} =0.8V V _{IHmin} =2.0V V _{IHmax} =3.6V	Low level active. If unused, keep this pin open or connect it to VCC.
UART Port					
Pin Name	Pin No.	I/O	Description	DC Characteristics	Comment
RXD	3	I	Receive data	V _{ILmin} =-0.3V V _{ILmax} =0.8V V _{IHmin} =2.0V V _{IHmax} =3.6V	
TXD	2	O	Transmit data	V _{OLmin} =-0.3V V _{OLmax} =0.4V V _{OHmin} =2.4V V _{OHmax} =3.1V	
RF Interface					
Pin Name	Pin No.	I/O	Description	DC Characteristics	Comment
RF_IN	11	I	External active antenna RF input		Characteristic impedance of 50Ω
VCC_RF	14	P	Active antenna power output	V _{nom} =3.3V	Linear regulator power output, 3.3V (Do not use this as power source of backup battery)

Other Interfaces					
Pin Name	Pin No.	I/O	Description	DC Characteristics	Comment
PPS	4	O	One pulse per second	VOLmin=-0.3V VOLmax=0.4V VOHmin=2.4V VOHmax=3.1V	Synchronized at rising edge, the pulse width is 100ms. If unused, keep this pin open.
EXTINT0	5	I/O	External Interrupt Pin		
VCC_IO	7		IO Supply Voltage	VOLmin=-0.3V VOLmax=0.4V VOHmin=2.52V VOHmax=3.08V	
ANT_NO	13		Antenna control	Vnom=3.3V	
V_ANT	15		Active Antenna Supply Voltage	Vnom=3.3V	
SDA	16	O	DDC Data	VILmin=-0.3V VILmax=0.8V VIHmin=2.0V VIHmax=3.6V	
SCL	17	I	DDC Clock	VILmin=-0.3V VILmax=0.8V VIHmin=2.0V VIHmax=3.6V	
Reserved	18	I/O	Reserved	Vnom=2.7V	

2.3. Power Supply

VCC pin supplies power for BB, RF, I/O, LNA, Antenna. The load current of VCC varies according to the VCC level, processor load, the number of tracked satellites and the rate of satellite re-acquisition. Using external active antenna will consume additional 11mA from our module. So it is important to supply sufficient current and make the power clean and stable. VCC supply ripple voltage should meet the requirement: 54mV (RMS) max @f=0~3MHz and 15mV (RMS) max @f>3MHz. You should choose the LDO without built-in output high-speed discharge function to keep long output voltage drop-down period. The decouple combination of 10uF and 100nF capacitor is recommended nearby VCC pin.

The VBAT pin supplies power for RTC domain. It should be valid when power on the module. The voltage of RTC domain ranges from 1.8V to 4.3V. In order to achieve a better TTFF, RTC domain should be valid all the time. It can supply power for SRAM memory in RTC domain which contains all the necessary GPS information for quick start-up and a small amount of user configuration variables.

✧ The module's internal power construction is shown as below.

VCC supplies power for PMU, and VBAT supplies power for RTC domain. TIMER signal highlighted in red in the following figure belongs to RTC domain and can be used to control the power switch on/off.

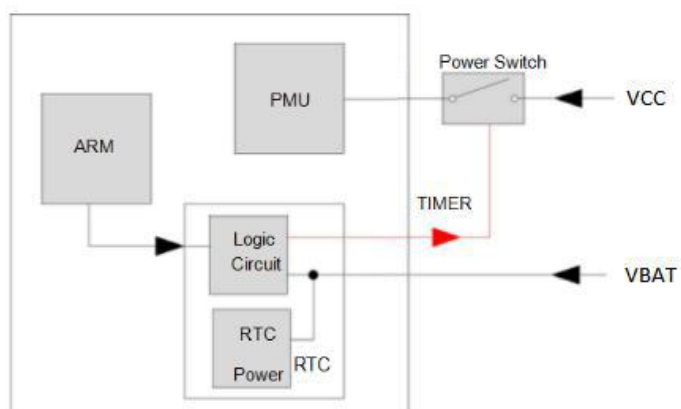

Figure 3: Internal Power Construction

✧ Power supply solutions for GT-1110U-GKBD module are listed as the following.

The simplest power circuit for GT-1110U-GKBD module is 3.3V power source connected to VCC pin and VBAT pin of the module directly. In this case, once you powered on the module, the full cold start will be implemented.

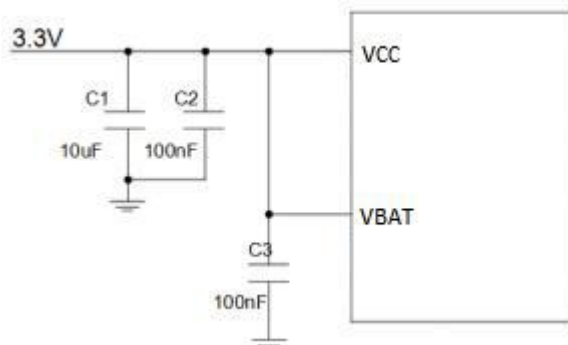

Figure 4: Reference Circuit for Power Supply

- ✧ If your power supply circuit adopts the design mentioned above , GT-1110U-GKBD module does not support backup mode.

The other way is feeding VBAT through a backup battery directly. The module will enter into backup mode when power source (3.3V) is cut off. Furthermore, it is necessary to add an external charging circuit for rechargeable battery. The detailed schematic (mount R2 with 0R to replace Power switch) is shown as there is no charge source when power source (3.3V) is cut off. MS621FE FL11E from Seiko is recommended. The consumption of VBAT is as low as 20uA in backup mode.

The schematic with power supply circuit is shown as below. As power source (3.3V) is always valid and the battery is charged continuously, the capacity of the battery can be small. The detailed schematic for power switch circuit is shown in **Figure 5**.

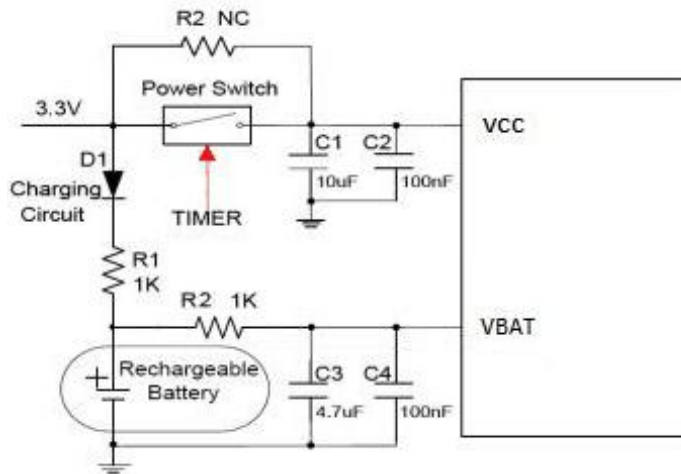

Figure 5: Reference Charging Circuit for Chargeable Battery

VCC does not supply power for RTC domain in GT-1110U-GKBD module, so the VBAT pin must be powered externally. Furthermore, it is strongly recommended to supply power to VBAT through a backup battery, which can ensure GT-1110U-GKBD module improves TTFF after next restart. For details about TTFF.

2.4. UART Interface

The module provides one universal asynchronous receiver& transmitter serial port. The module is designed as DCE (Data Communication Equipment), following the traditional DCE-DTE (Data Terminal Equipment) connection. The module and the client (DTE) are connected through the signals shown in the following figure. It supports data baud-rate from 4800bps to 115200bps.

UART port:

TXD: Send data to the RXD signal line of DTE.

RXD: Receive data from the TXD signal line of DTE..

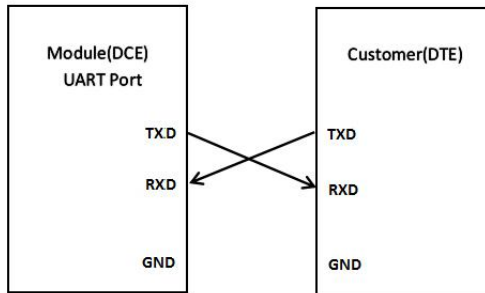

Figure 6: Connection of Serial Interfaces

This UART port has the following features:

- UART port can be used for NMEA output and proprietary commands input.
- The default output NMEA type setting is RMC, GGA, GSA, GSV, GLL, VTG
- UART port supports the following data rates:
4800, 9600, 14400, 19200, 38400, 57600, 115200bps.
The default setting is 9600bps, 8 bits, no parity bit, 1 stop bit.
- Hardware flow control and synchronous operation are not supported.

The UART port does not support the RS-232 level but only CMOS level. If the module's UART port is connected to the UART port of a computer, it is necessary to add a level shift circuit between the module and the computer. Please refer to the following figure.

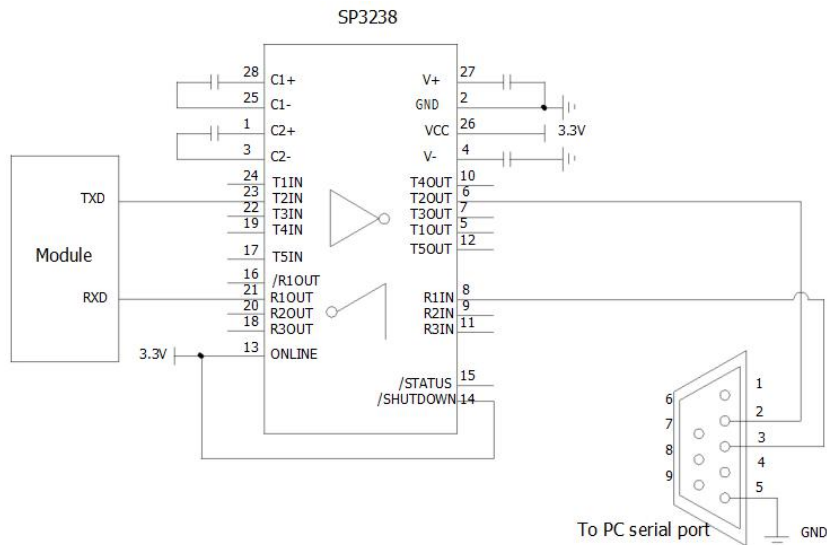

Figure 7: RS-232 Level Shift Circuit

2.5. PPS VS. NMEA

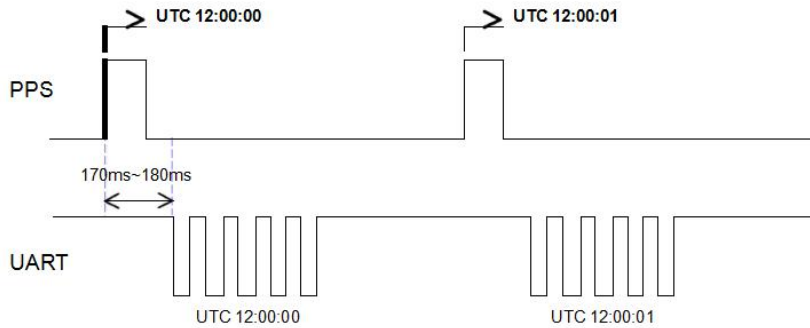

Figure 8: PPS VS. NMEA Timing

This feature only supports 1Hz NMEA output and baud rate at 14400~115200bps. At baud rate of 9600 and 4800bps, it only supports RMC NMEA sentence. Because at low baud rate, per second transmission may exceed one second if there are many NMEA sentences output.

3 Antenna Interfaces

3.1. PCB Design Guide

The GT-1110U-GKBD GPS receiver is designed for supporting the active antenna or passive antenna connected with pin RF_IN. The gain of active antenna should be no less than 15dB. The maximum noise figure should be no more than 2.5dB and output impedance is at 50 Ohm.

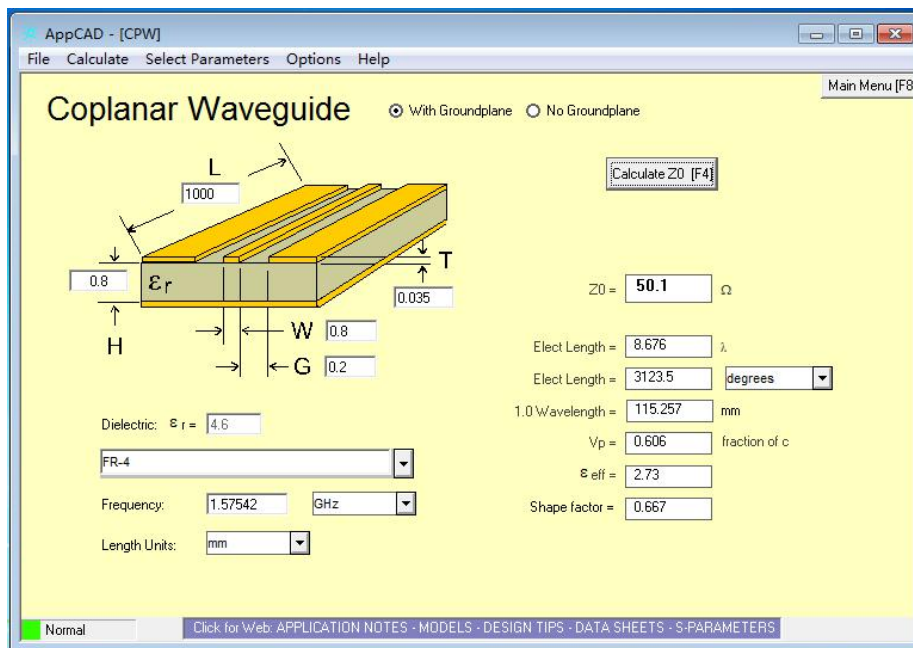

Figure 9: Antenna design requirements

3.2. External Active Antenna

The following figure is a typical reference design with active antenna. In this mode, DC on the VCC_RF pin is powered by VCC and supplies power to the external active antenna.

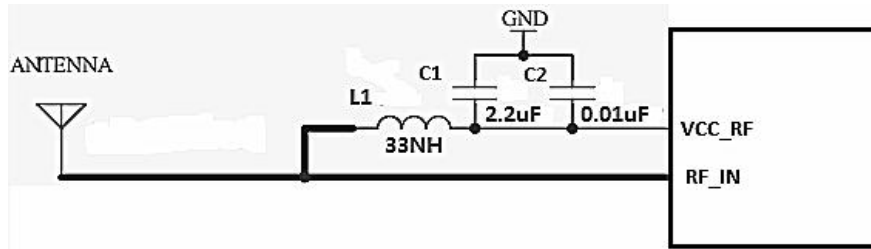

Figure 10: Reference Design for Active Antenna

C1, C2, L1 is used for power supply and filtering effect to the external active antenna, The L1 position recommends the use of 27NH or 33NH high frequency stacked inductors; RF_IN antenna to a circuit part (BOLD line) for high frequency microstrip line, PCB in the design of this part of the line to calculate the characteristic impedance of the high-frequency line according to the principle of high frequency wiring.

- ◇ Requirements: this section of the line in the 1575.42MHz frequency characteristic impedance requirement is 50 ohm.

Table 2: Recommended Active Antenna Specification

Antenna Type	Specification
Active Antenna	Center frequency: 1575.42MHz Band width: >5MHZ VSWR: <2 (Typ.) Polarization: RHCP or Linear Noise figure: <1.5dB Gain (antenna): >-2dBi Gain (embedded LNA): 20dB (Typ.) Total gain: >18dBi(Typ.)

4 Electrical, Reliability and Radio Characteristics

4.1. Absolute Maximum Ratings

Absolute maximum ratings for power supply and voltage on digital pins of the module are listed in the following table.

Table 3: Absolute Maximum Ratings

values within the specified boundaries by using appropriate protection diodes.

Parameter	Min.	Max.	Unit
Power Supply Voltage (VCC)	-0.3	4.3	V
Backup Battery Voltage (VBAT)	-0.3	4.3	V
Input Voltage at Digital Pins	-0.3	3.6	V
Input Power at RF_IN		15	dBm
Storage Temperature	-45	125	°C

- ✧ Stressing the device beyond the “Absolute Maximum Ratings” may cause permanent damage. These are stress ratings only. The product is not protected against over voltage or reversed voltage. If necessary, voltage spikes exceeding the power supply voltage specification, given in table above, must be limited to values within the specified boundaries by using appropriate protection diodes.

4.2. Operating Conditions

Table 4: Power Supply Ratings

Parameter	Description	Conditions	Min.	Typ.	Max.	Unit
VCC	Supply voltage	Voltage must stay within the min/max values, including voltage drop, ripple, and spikes.	2.8	3.3	4.3	V
IVCCP	Peak supply current	VCC=3.3V			100	mA
VBAT	Backup voltage supply		1.5	3.3	4.3	V
TOPR	Normal operating temperature		-40	25	80	°C

- ◇ The figure IVCCP can be used to determine the maximum current capability of power supply.
- ◇ Operation beyond the "Operating Conditions" is not recommended and extended exposure beyond the "Operating Conditions" may affect the device's reliability.

4.3. Current Consumption

The values for current consumption are shown in the following table.

Table 5: Current Consumption

Parameter	Conditions	Min.	Typ.	Max.	Unit
I _{VCC} @Acquisition	VCC=VBAT=3.3V		40		mA
I _{VCC} @Tracking	VCC=VBAT=3.3V		35		mA
I _{VCC} @Standby	VCC=VBAT=3.3V		2.0		mA
I _{BCKP} @Backup	VBAT=3.3V		15		uA

The tracking current is tested in the following conditions:

- ◇ In Cold Start, 10 minutes after First Fix.
- ◇ In Hot Start, 15 seconds after First Fix.

4.4. Electrostatic Discharge

GT-1110U-GKBD module is an ESD sensitive device. ESD protection precautions should still be emphasized. Proper ESD handling and packaging procedures must be applied throughout the processing, handling and operation of any application.

The ESD bearing capability of the module is listed in the following table. Note that you should add ESD components to module pins in particular applications.

Table 6: ESD Endurance Table (Temperature : 25°C, Humidity: 45%)

Pin	Contact Discharge	Air Discharge
RF_IN	±5KV	±10KV
VCC	±5KV	±10KV
UART	±3KV	±6KV
Others	±2KV	±4KV

4.5. Reliability Test

Table 12: Reliability Test

Test Item	Conditions	Standard
Thermal Shock	-30°C...+80°C, 144 cycles	GB/T 2423.22-2002 Test Na IEC 68-2-14 Na
Damp Heat, Cyclic	+55°C; >90% Rh 6 cycles for 144 hours	IEC 68-2-30 Db Test
Vibration Shock	5~20Hz, 0.96m2/s3; 20~500Hz, 0.96m2/s3-3dB/oct, 1hour/axis; no function	2423.13-1997 Test Fdb IEC 68-2-36 Fdb Test
Heat Test	85°C, 2 hours, operational	GB/T 2423.1-2001 Ab IEC 68-2-1 Test
Cold Test	-40°C, 2 hours, operational	GB/T 2423.1-2001 Ab IEC 68-2-1 Test
Heat Soak	90°C, 72 hours, non-operational	GB/T 2423.2-2001 Bb IEC 68-2-2 Test B
Cold Soak	-45°C, 72 hours, non-operational	GB/T 2423.1-2001 A IEC 68-2-1 Test

5 Mechanical Dimensions

This chapter describes the mechanical dimensions of the module.

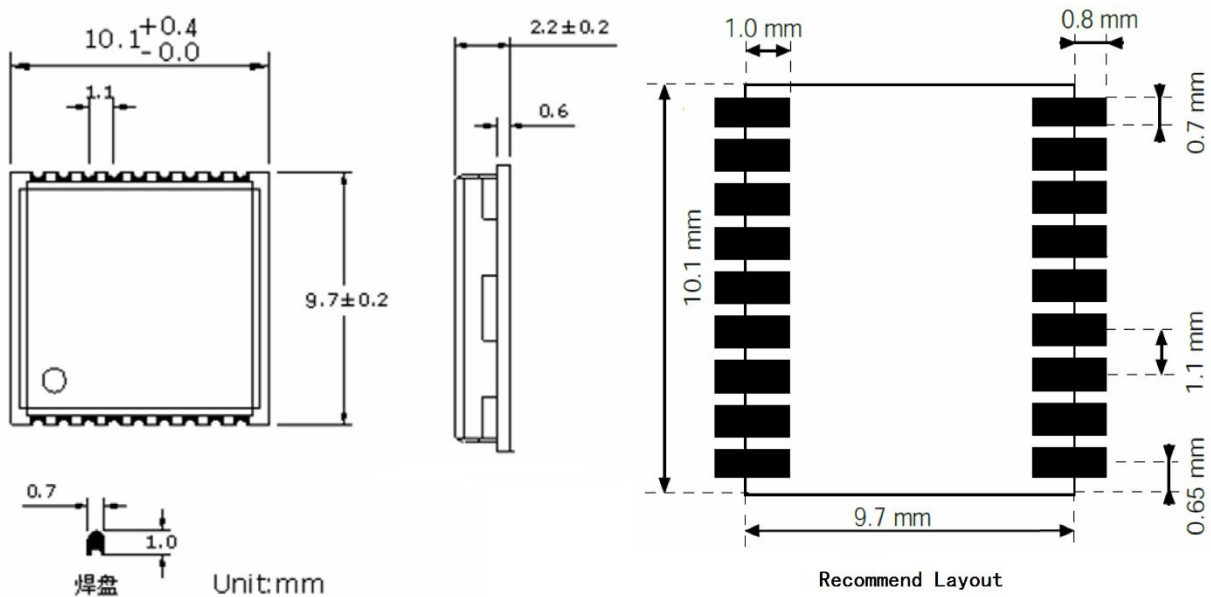

Figure 10: Module Size chart

6 Manufacturing, Packaging and Ordering Information

6.1. Assembly and Soldering

GT-1110U-GKBD module is intended for SMT assembly and soldering in a Pb-free reflow process on the top side of the PCB. It is suggested that the minimum height of solder paste stencil is 100um to ensure sufficient solder volume. Pad openings of paste mask can be increased to ensure proper soldering and solder wetting over pads. It is suggested that the peak reflow temperature is 235~245° C (for SnAg3.0Cu0.5 alloy). The absolute maximum reflow temperature is 260° C. To avoid damage to the module when it is repeatedly heated, it is suggested that the module should be mounted after reflow soldering for the other side of PCB has been completed. Recommended reflow soldering thermal profile is shown below:

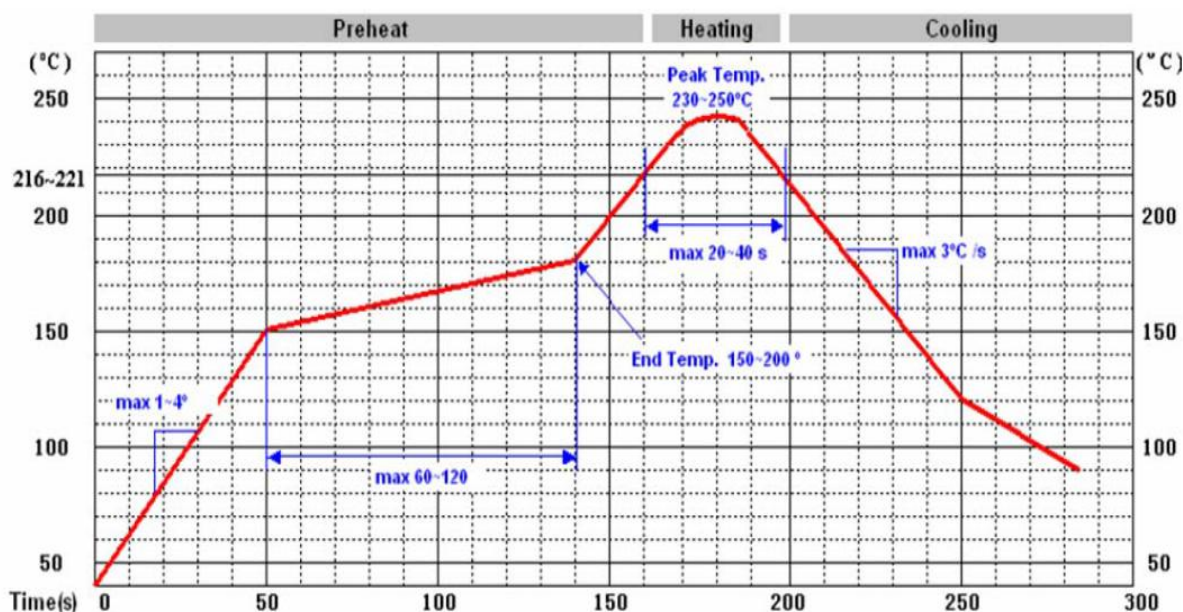

Figure 11: Recommended Reflow Soldering Thermal Profile

6.2. Moisture Sensitivity

GT-1110U-GKBD module is sensitive to moisture. To prevent GT-1110U-GKBD from permanent damage during reflow soldering, baking before reflow soldering is required in following cases:

- ◇ Humidity indicator card: One or more indicating spots are no longer blue.
- ◇ The seal is opened and the module is exposed to excessive humidity.

GT-1110U-GKBD should be baked for 192 hours at temperature 40°C+5°C/-0°C and <5% RH in low-temperature containers, or 24 hours at temperature 125°C±5°C in high-temperature containers. Care should be taken that the plastic tape is not heat resistant. GT-1110U-GKBD should be taken out from the tape before preheating; otherwise, the tape maybe damaged by high-temperature heating.

6.3. ESD Protection

GT-1110U-GKBD module is sensitive to ESD and requires special precautions when handling. Particular care must be exercised when handling patch antenna, due to the risk of electrostatic charges.

6.4. Tape and Reel Packaging

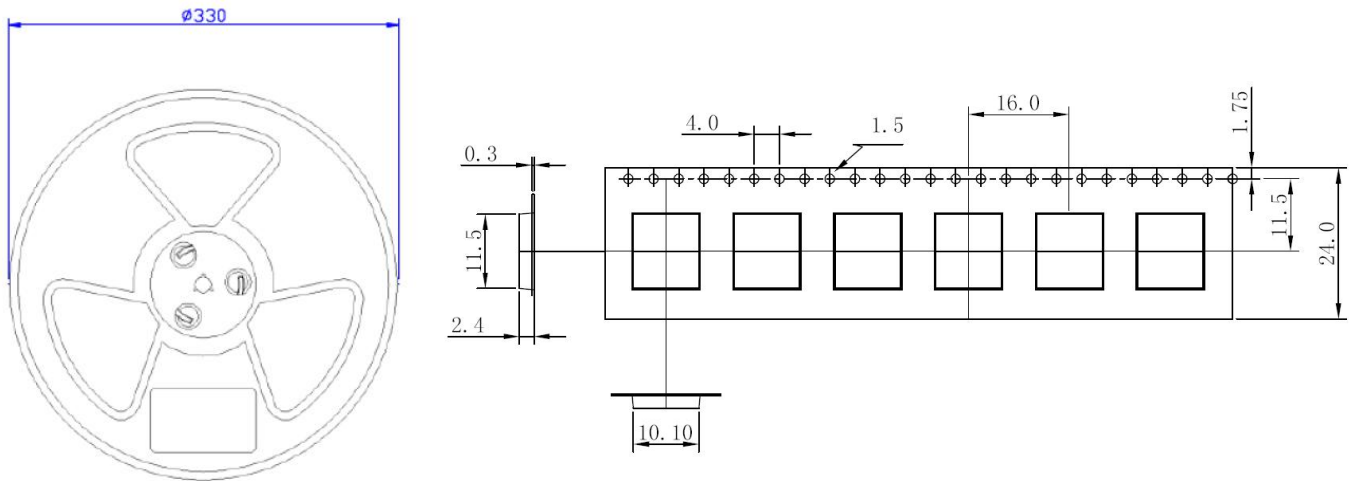

Unit: mm

Quantity per reel: 1000pcs

Length per reel: 16m

Figure 12: Tape and Reel Specifications



Figure 13: Packaging physical Figure

Table13: Reel Packaging

Model Name	MOQ for MP	Minimum Package: 1000pcs
GT-1110U-GKBD	1000pcs	Size: 365mm × 350mm × 53mm N.W: 0.87kg G.W: 1.05kg

7 Appendix References

Table 9: Terms and Abbreviations

Abbreviation	Description
AGNSS	Assisted Global navigation satellite system
DGPS	Differential GPS
ESD	Electrostatic Discharge
GPS	Global Positioning System
GNSS	Global Navigation Satellite System
GGA	GPS Fix Data
GLL	Geographic Position – Latitude/Longitude
GLONASS	Global Navigation Satellite System
GSA	GPS DOP and Active Satellites
GSV	GPS Satellites in View
HDOP	Horizontal Dilution of Precision
I/O	Input/Output
Kbps	Kilo Bits Per Second
LNA	Low Noise Amplifier
MSAS	Multi-Functional Satellite Augmentation System
MOQ	Minimum Order Quantity
NMEA	National Marine Electronics Association
PDOP	Position Dilution of Precision
PPS	Pulse Per Second
PRN	Pseudo Random Noise Code
QZSS	Quasi-Zenith Satellite System
RHCP	Right Hand Circular Polarization
RMC	Recommended Minimum Specific GPS Data
SBAS	Satellite-based Augmentation System
SAW	Surface Acoustic Wave
SPDT	Single-Pole Double-Throw
TTFF	Time To First Fix

UART	Universal Asynchronous Receiver & Transmitter
VDOP	Vertical Dilution of Precision
VTG	Course over Ground and Ground Speed, Horizontal Course and Horizontal Velocity
WAAS	Wide Area Augmentation System
Inom	Nominal Current
Imax	Maximum Load Current
Vmax	Maximum Voltage Value
Vnom	Nominal Voltage Value
Vmin	Minimum Voltage Value
VIHmax	Maximum Input High Level Voltage Value
VIHmin	Minimum Input High Level Voltage Value
VILmax	Maximum Input Low Level Voltage Value
VILmin	Minimum Input Low Level Voltage Value
VImax	Absolute Maximum Input Voltage Value
VImin	Absolute Minimum Input Voltage Value
VOHmax	Maximum Output High Level Voltage Value
VOHmin	Minimum Output High Level Voltage Value
VOLmax	Maximum Output Low Level Voltage Value
VOLmin	Minimum Output Low Level Voltage Value

8 Configuration instruction Explain

The module supports the commonly used commands in configuration, The following table describes some of the parameters of the UART port configuration command, The Module power up initialization requires 300ms, Please send the sixteen system from CPU via serial port.

Table 10: Common instruction

Common commands	Instructions
Cold star	\$PGKC030,3,1*2E <CR><LF>
Warm start	\$PGKC030,2,1*2F <CR><LF>
Hot start	\$PGKC030,1,1*2C <CR><LF>
Reset	\$PGKC030,3,1*2E <CR><LF>
LOW Power	\$PGKC105,8*3F <CR><LF>
Baud rate is 4800bps	\$PGKC147,4800*D <CR><LF>
Baud rate is 9600bps	\$PGKC147,9600*E <CR><LF>
Baud rate is 19200bps	\$PGKC147,19200*3B <CR><LF>
Baud rate is 38400bps	\$PGKC147,38400*3E <CR><LF>
Baud rate is 57600bps	\$PGKC147,57600*35 <CR><LF>
Baud rate is 115200bps	\$PGKC147,115200*6 <CR><LF>

9 NMEA 0183 Protocol

The NMEA protocol is an ASCII-based protocol, Records start with a \$ and with carriage return/line feed. GPS+Beidou specific messages all start with \$GPxxx/\$BDxxx where \$GNxxx is a three-letter identifier of the message data that follows. NMEA messages have a check sum, which allows detection of corrupted data transfers.

This module supports three modes of instruction configuration, each mode corresponding to the NMEA data such as *Table 11*.

Table 11: Each mode corresponds to the NMEA data

Pattern	NMEA Out Put
GPS&Beidou \$PGKC115,1,0,1,0*2A <CR><LF>	GNRMC.GNGGA.GPGSV.BDGSA.BDGSA. GNGLL.GNVTG

- ◇ The Gotop GT-1110U-GKBD Initialization location mode for GPS&Beidou dual mode,
Output data: \$GNRMC.\$GNGGA.\$GPGSV.\$BDGSA.\$BDGSA.\$GNGLL.\$GNVTG.

NMEA-0183 Output Messages

NMEA Record	DESCRIPTION
GGA	Global positioning system fixed data
GLL	Geographic position—latitude/longitude
GSA	GNSS DOP and active satellites
GSV	GNSS satellites in view
RMC	Recommended minimum specific GNSS data
VTG	Course over ground and ground speed

9.1 GGA-Global Positioning System Fixed Data

\$xxGGA, 161229.487,3723.2475,N, 12158.3416,W, 1,07,1.0,9.0,M.0000*18

Table 12: GGA Data Format

Name	Example	Units	Description
Message ID	\$xxGGA		GGA protocol header
UTC Position	161229.487		hhmmss.sss
Latitude	3723.2457		ddmm.mmmm
N/S indicator	N		N=north or S=south
Longitude	12158.3416		dddmm.mmmm
E/W Indicator	W		E=east or W=west
Position Fix Indicator	1		See Table 12-1
Satellites Used	07		Range 0 to 12
HDOP	1.0		Horizontal Dilution of Precision
MSL Altitude	9.0	meters	
Units	M	meters	
Geoids Separation		meters	
Units	M	meters	
Age of Diff.Corr.		second	Null fields when DGPS is not Used
Diff.Ref.Station ID	0000		
Check sum	*18		
<CR> <LF>			End of message termination

Table 12-1: Position Fix Indicators

Value	Description
0	Fix not available or invalid
1	GPS SPS Mode, fix valid
2	Differential GPS, SPS Mode, fix valid
3	GPS PPS Mode, fix valid

9.2 GLL-Geographic Position – Latitude/Longitude

\$xxGLL , 3723.2475, N,12158.3416, W,161229.487, A*2C.

Table 13: GLL Data Format

Name	Example	Units	Description
Message ID	\$xxGLL		GLL protocol header
Latitude	3723.2475		ddmm.mmmm
N/S Indicator	N		N=north or S=south
Longitude	12158.3416		dddmm.mmmm
E/W Indicator	W		E=east or W=west
UTC Position	161229.487		hhmmss.sss
Status	A		A=data valid or V=data not valid
Check sum	*2C		
<CR> <LF>			End of message termination

9.3 GSA-GPS DOP and Active Satellites

\$xxGSA , A, 3, 07, 02, 26,27, 09, 04,15, , , , , 1.8,1.0,1.5*33.

Table 14: GSA Data Format

Name	Example	Units	Description
Message	\$xxGSA		GSA protocol header
Mode 1	A		See Table 14-2
Mode 2	3		See Table 14-1
Satellite Used	07		Sv on Channel 1
Satellite Used	02		Sv on Channel 2
...
Satellite Used			Sv on Channel 66
PDOP	1.8		Position Dilution of Precision
HDOP	1.0		Horizontal Dilution of Precision
VDOP	1.5		Vertical Dilution of Precision
Check sum	*33		
<CR> <LF>			End of message termination

Table 14-1: Mode 1

Value	Description
1	Fix not available
2	2D
3	3D

Table 14-2: Mode 2

Value	Description
M	Manual-forced to operate in 2D or 3D mode
A	Automatic-allowed to automatically switch 2D/3D

9.4 GSV-GPS Satellites in View

\$xxGSV , 2, 1, 07, 07, 79,048, 42, 02, 51,062, 43, 26, 36,256, 42, 27, 27, 138,42*71

\$xxGSV, 2, 2, 07, 09, 23,313, 42, 04, 19, 159, 41, 15,12,041, 42*41.

Table 15: GGA Data Format

Name	Example	Units	Description
Message ID	\$xxGSV		GSV protocol header
Number of Message	2		Range 1 to 3
Message Number	1		Range 1 to 3
Satellites in View	07		
Satellite ID	07		Channel 1(Range 1 to 66)
Elevation	79	degrees	Channel 1(Maximum 90)
Azinmuth	048	degrees	Channel 1(True, Range 0 to 359)
SNR(C/NO)	42	dBHz	Range 0 to 99,null when not tracking
...			...
Satellite ID	27		Channel 4(Range 1 to 66)
Elevation	27	degrees	Channel 4(Maximum 90)
Azimuth	138	degrees	Channel 4(True, Range 0 to 359)
SNR(C/NO)	42	dBHz	Range 0 to 99, null when not tracking
Check sum	*71		
<CR> <LF>			End of message termination

Depending on the number of satellites tracked multiple messages of GSV data may be required.

9.5 RMC-Recommended Minimum Specific GPS Data

\$xxRMC, 161229.487, A, 3723.2475, N, 12158.3416, W, 0.13,309.62, 120598,, *10

Table 16: RMC Data Format

Name	Example	Units	Description
Message ID	\$xxRMC		RMC protocol header
UTS Position	161229.487		hhmmss.sss
Status	A		A=data valid or V=data not valid
Latitude	3723.2475		ddmm.mmmm
N/S Indicator	N		N=north or S=south
Longitude	12158.3416		dddmm.mmmm
E/W Indicator	W		E=east or W=west
Speed Over Ground	0.13	Knots	
Course Over	309.62	Degrees	True
Ground			
Date	120598		Dummy
Magnetic variation		Degrees	E=east or W=west
Check sum	*10		
<CR> <LF>			End of message termination

9.6 VTG-Course Over Ground and Ground Speed

\$xxVTG, 309.62, T, M, 0.13, N, 0.2, K*6E

Table 17: VTG Data Format

Name	Example	Units	Description
Message ID	\$xxVTG		VTG protocol header
Course	309.62	Degrees	Measured heading
Reference	T		True
Course		Degrees	Measured heading
Reference	M		Magnetic
Speed	0.13	Knots	Measured horizontal speed
Units	N		Knots
Speed	0.2	Km/hr	Measured horizontal speed
Units	K		Kilometer per hour
Check sum	*6E		
<CR> <LF>			End of message termination

©Copyright 2020 Gotop Technology Co., Ltd. All Right Reserved

The information contained herein is subject to change without notice.

Gotop Technology Co. , LTD

Add:AreaC,4th layer,A1 building,QingHu Silicon Valley Power,LongHua district ,Shenzhen ,China

Phone: 86-755-23804156

fax: 86-755-23804155

N 22° 32' 17", E 114° 07' 07"

<http://www.gotop-zzu.com>

Not to be reproduced in whole or part for any purpose without written permission of Gotop Technology Inc ('Gotop'). Information provided by Gotop is believed to be accurate and reliable. These materials are provided by Gotop as a service to its customers and may be used for informational purposes only. Gotop assumes no responsibility for errors or omissions in these materials, nor for its use. Gotop reserves the right to change specification at any time without notice.

These materials are provides 'as is' without warranty of any kind, either expressed or implied, relating to sale and/or use of Gotop products including liability or warranties relating to fitness for a particular purpose, consequential or incidental damages, merchantability, or infringement of any patent, copyright or other intellectual property right. Gotop further does not warrant the accuracy or completeness of the information, text, graphics or other items contained within these materials. Gotop shall not be liable for any special, indirect, incidental, or consequential damages, including without limitation, lost revenues or lost profits, which may result from the use of these materials.

Gotop products are not intended for use in medical, life-support devices, or applications involving potential risk of death, personal injury, or severe property damage in case of failure of the product.