

## General Description

The Gotop GT-1110-TDBD is a complete GPS&Beidou engine module that features super sensitivity, ultra low power and small form factor. The GPS&Beidou signal is applied to the antenna input of module, and a complete serial data message with position, velocity and time information is presented at the serial interface with NMEA protocol or custom protocol.

Its  $-163\text{dBm}$  tracking sensitivity extends positioning coverage into place like urban canyons and dense foliage environment where the GPS&Beidou was not possible before. The small form factor and low power consumption make the module easy to integrate into portable device like PNDs, mobile phones, cameras and vehicle navigation systems.

### Applications

- LBS (Location Based Service)
- PND (Portable Navigation Device)
- Vehicle navigation system
- Mobile phone



**Figure: GT-1110-TDBD Top View**

### Features

- Build on high performance, low-power Taidou TD1030 chip set
- Ultra high Track sensitivity:  $-163\text{dBm}$
- Extremely fast TTFB at low signal level
- Low power consumption: Max  $25\text{mA}@3.3\text{V}$
- NMEA-0183 compliant protocol or custom protocol
- Operating voltage:  $2.8\text{V}$  to  $3.6\text{V}$
- Operating temperature range:  $-40$  to  $85^\circ\text{C}$
- SMD type with stamp holes
- Small form factor:  $10.1 \times 9.7 \times 2.2\text{mm}$
- RoHS compliant (Lead-free)

<b>1 Description</b> .....	3
1.1. Key Features.....	3
1.2. Block Diagram.....	4
<b>2 Application</b> .....	4
2.1. Pin Assignment.....	4
2.2. Pin Definition.....	5
2.3. Power Supply.....	6
2.4. UART Interface.....	8
2.5. PPS VS. NMEA.....	9
<b>3 Antenna Interfaces</b> .....	10
3.1. PCB Design Guide.....	10
3.2. External Active Antenna.....	10
<b>4 Electrical, Reliability and Radio Characteristics</b> .....	11
4.1. Absolute Maximum Ratings.....	11
4.2. Operating Conditions.....	12
4.3. Current Consumption.....	12
4.4. Electrostatic Discharge.....	13
<b>5 Mechanical Dimensions</b> .....	13
<b>6 Manufacturing, Packaging and Ordering Information</b> .....	14
6.1. Assembly and Soldering.....	14
6.2. Moisture Sensitivity.....	14
6.3. ESD Protection.....	14
6.4. Tape and Reel Packaging.....	错误! 未定义书签。
<b>7 Appendix References</b> .....	16
<b>8 NMEA 0183 Protocol</b> .....	17
8.1 GGA-Global Positioning System Fixed Data.....	18
8.2 GSA-GNSS DOP and Active Satellites.....	18
8.3 GSV-GNSS Satellites in View.....	20
8.4 RMC-Recommended Minimum Specific GNSS Data.....	20

# 1 Description

## 1.1. Key Features

**Table 1: Key Features**

Parameter	Specification
Power Supply	<ul style="list-style-type: none"> <li>Supply voltage: 2.8V~3.6V Typical: 3.3V</li> </ul>
Power Consumption	<ul style="list-style-type: none"> <li>Acquisition: 25mA @VCC=V_BCKP=3.3V</li> <li>Tracking: 20mA @VCC=V_BCKP=3.3V</li> <li>Backup: 15uA @V_BCKP=3.3V</li> </ul>
Receiver Type	<ul style="list-style-type: none"> <li>Code 56 search channels</li> <li>GPS&amp;QZSS L1 1575.42MHz C/A , Beidou B1 1561.098MHz</li> <li>SBAS: WAAS, EGNOS, MSAS, GAGAN</li> </ul>
Sensitivity	<ul style="list-style-type: none"> <li>Tracking: -163dBm</li> <li>Re-acquisition: -156dBm</li> <li>Acquisition: -147dBm</li> </ul>
TTF	<ul style="list-style-type: none"> <li>Cold start: 35s typ @-130dBm</li> <li>Warm start: 30s typ @-130dBm</li> <li>Hot start: 1s typ @-130dBm</li> </ul>
Horizontal Position Accuracy (Autonomous)	<ul style="list-style-type: none"> <li>&lt;2.5m CEP @-130 dBm</li> </ul>
Update Rate	<ul style="list-style-type: none"> <li>1Hz</li> </ul>
Accuracy of 1PPS Signal	<ul style="list-style-type: none"> <li>Typical accuracy: ±10ns</li> <li>Time pulse width : 100ms</li> </ul>
Acceleration Accuracy	<ul style="list-style-type: none"> <li>Without aid: 0.1m/s<sup>2</sup></li> </ul>
Dynamic Performance	<ul style="list-style-type: none"> <li>Maximum altitude: 18,000m</li> <li>Maximum velocity: 515m/s</li> <li>Acceleration: 4G</li> </ul>
UART Port	<ul style="list-style-type: none"> <li>UART Port: TXD and RXD</li> <li>Supports baud rate from 4800bps to 115200bps, 9600bps by default</li> <li>UART port is used for NMEA output, Taidou proprietary commands input</li> </ul>
Temperature Range	<ul style="list-style-type: none"> <li>Normal operation: -40°C ~ +85°C</li> <li>Storage temperature: -45°C ~ +125°C</li> </ul>
Physical Characteristics	<ul style="list-style-type: none"> <li>Size: 10.1±0.15 × 9.7±0.15 × 2.2±0.1mm</li> <li>Weight: Approx. 0.41g</li> </ul>

## 1.2. Block Diagram

The following figure shows a block diagram of GT-1110-TDBD module. It consists of a single chip GNSS IC which includes the RF part and Baseband part, a SAW filter, a TCXO, a crystal oscillator.

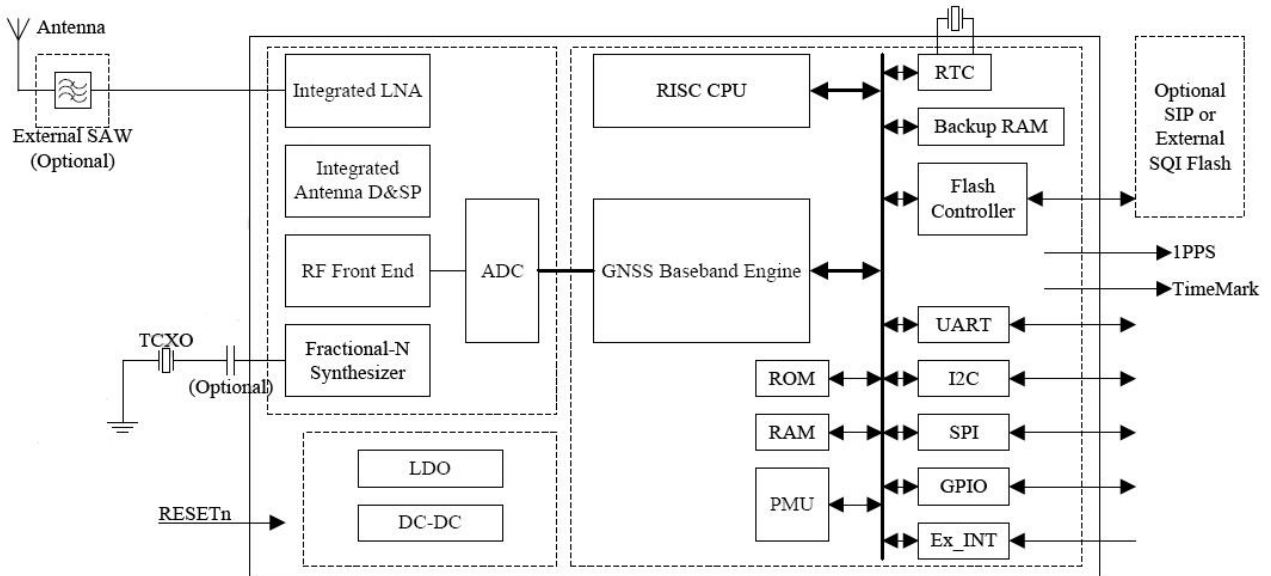

**Figure 1:** Block Diagram

## 2 Application

The module is equipped with a 18-pin SMT pad that connects to your application platform. Sub-interfaces included in the pad are described in details in the following chapters.

### 2.1. Pin Assignment



**Figure 2:** Pin Assignment

## 2.2. Pin Definition

Power Supply					
Pin Name	Pin No.	I/O	Description	DC Characteristics	Comment
VCC	8	I	Main power supply	V <sub>max</sub> =3.6V V <sub>min</sub> =2.8V V <sub>nom</sub> =3.3V	Supply current not less than 100mA.
VBAT	6	I	Backup power supply	V <sub>max</sub> =3.6V V <sub>min</sub> =1.5V V <sub>nom</sub> =3.3V	Supply power for RTC domain. The VBAT pin can be directly supplied power by battery or connect it to VCC.
GND	1.10. 12	G	Ground.		Assure a good GND connection to all GND pins of the module, preferably with a large ground plane.
Other Interfaces					
Pin Name	Pin No.	I/O	Description	DC Characteristics	Comment
PPS	3	O	One pulse per second	V <sub>OLmin</sub> =-0.3V V <sub>OLmax</sub> =0.4V V <sub>OHmin</sub> =2.4V V <sub>OHmax</sub> =3.1V	Synchronized at rising edge, the pulse width is 100ms. If unused, keep this pin open.
UART Port					
Pin Name	Pin No.	I/O	Description	DC Characteristics	Comment
RXD	3	I	Receive data	V <sub>ILmin</sub> =-0.3V V <sub>ILmax</sub> =0.8V V <sub>IHmin</sub> =2.0V V <sub>IHmax</sub> =3.6V	
TXD	2	O	Transmit data	V <sub>OLmin</sub> =-0.3V V <sub>OLmax</sub> =0.4V V <sub>OHmin</sub> =2.4V V <sub>OHmax</sub> =3.1V	
RF Interface					
Pin Name	Pin No.	I/O	Description	DC Characteristics	Comment
RF_IN	11	I	External active antenna RF input		Characteristic impedance of 50Ω
VCC_RF	9	O	Active antenna power output	V <sub>nom</sub> =3.3V	Output Voltage RF section. VCC_RF can be selected according to the type of antenna.

### 2.3. Power Supply

VCC pin supplies power for BB, RF, I/O, Antenna. The load current of VCC varies according to the VCC level, processor load, the number of tracked satellites and the rate of satellite re-acquisition. Using external active antenna will consume additional 11mA from our module. So it is important to supply sufficient current and make the power clean and stable. VCC supply ripple voltage should meet the requirement: 54mV (RMS) max @f=0…3MHz and 15mV (RMS) max@f>3MHz. You should choose the LDO without built-in output high-speed discharge function to keep long output voltage drop-down period. The decouple combination of 10uF and 100nF capacitor is recommended nearby VCC pin.

The VBAT pin supplies power for RTC domain. It should be valid when power on the module. The voltage of RTC domain ranges from 1.8V to 3.6V. In order to achieve a better TTFF, RTC domain should be valid all the time. It can supply power for SRAM memory in RTC domain which contains all the necessary GPS&Beidou information for quick start-up and a small amount of user configuration variables.

✧ The module's internal power construction is shown as below.

VCC supplies power for PMU, and VBAT supplies power for RTC domain. TIMER signal highlighted in red in the following figure belongs to RTC domain and can be used to control the power switch on/off.

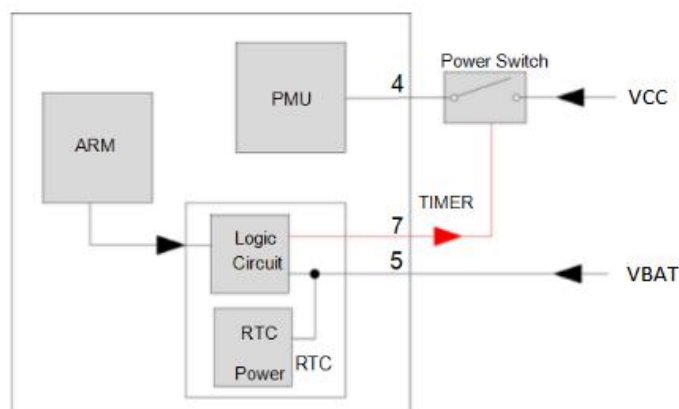

**Figure 3:** Internal Power Construction

✧ Power supply solutions for GT-1110-TDBD module are listed as the following.

The simplest power circuit for GT-1110-TDBD module is 3.3V power source connected to VCC pin and VBAT pin of the module directly. In this case, once you powered on the module, the full cold start will be implemented.

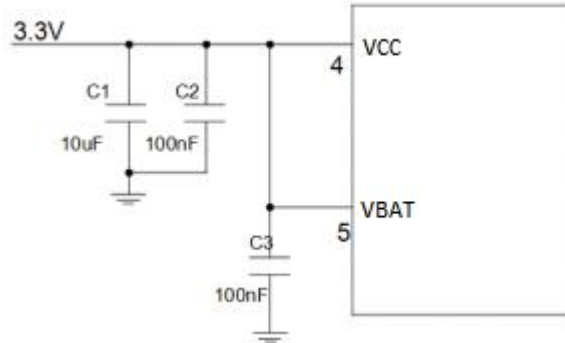
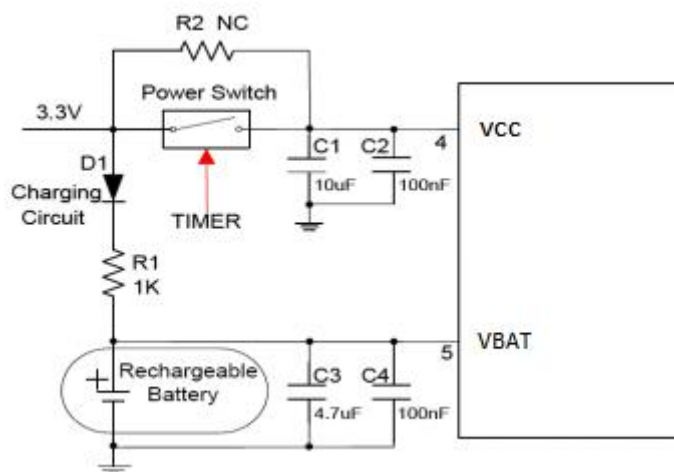

**Figure 4:** Reference Circuit for Power Supply

✧ If your power supply circuit adopts the design mentioned above , GT-1110-TDBD module does not support backup mode.

The other way is feeding VBAT through a backup battery directly. The module will enter into backup mode when power source (3.3V) is cut off. Furthermore, it is necessary to add an external charging circuit for rechargeable battery. The detailed schematic (mount R2 with 0R to replace Power switch) is shown as there is no charge source when power source (3.3V) is cut off. MS621FE FL11E from Seiko is recommended. The consumption of VBAT is as low as 15µA in backup mode.

The schematic with power supply circuit is shown as below. As power source (3.3V) is always valid and the battery is charged continuously, the capacity of the battery can be small. The detailed schematic for power switch circuit is shown in *Figure 5*.



**Figure 5:** Reference Charging Circuit for Chargeable Battery

VCC does not supply power for RTC domain in GT-1110-TDBD module, so the VBAT pin must be powered externally. Furthermore, it is strongly recommended to supply power to VBAT through a backup battery, which can ensure GT-1110-TDBD module improves TTFF after next restart. For details about TTFF.

## 2.4. UART Interface

The module provides one universal asynchronous receiver& transmitter serial port. The module is designed as DCE (Data Communication Equipment), following the traditional DCE-DTE (Data Terminal Equipment) connection. The module and the client (DTE) are connected through the signals shown in the following figure. It supports data baud-rate from 4800bps to 115200bps.

### UART port:

TXD: Send data to the RXD1 signal line of DTE.

RXD: Receive data from the TXD1 signal line of DTE.

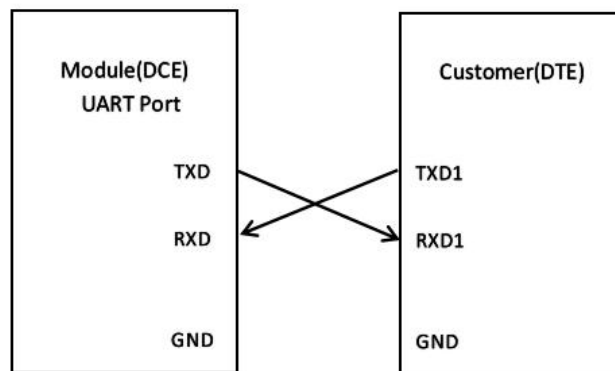

**Figure 6:** Connection of Serial Interfaces

### This UART port has the following features:

- UART port can be used for NMEA output and proprietary commands input.
- The default output NMEA type setting is RMC, GGA, GSA, GSV,
- UART port supports the following data rates:  
4800, 9600, 14400, 19200, 38400, 57600, 115200bps.  
The default setting is 9600bps, 8 bits, no parity bit, 1 stop bit.
- Hardware flow control and synchronous operation are not supported.



The UART port does not support the RS-232 level but only CMOS level. If the module's UART port is connected to the UART port of a computer, it is necessary to add a level shift circuit between the module and the computer. Please refer to the following figure.

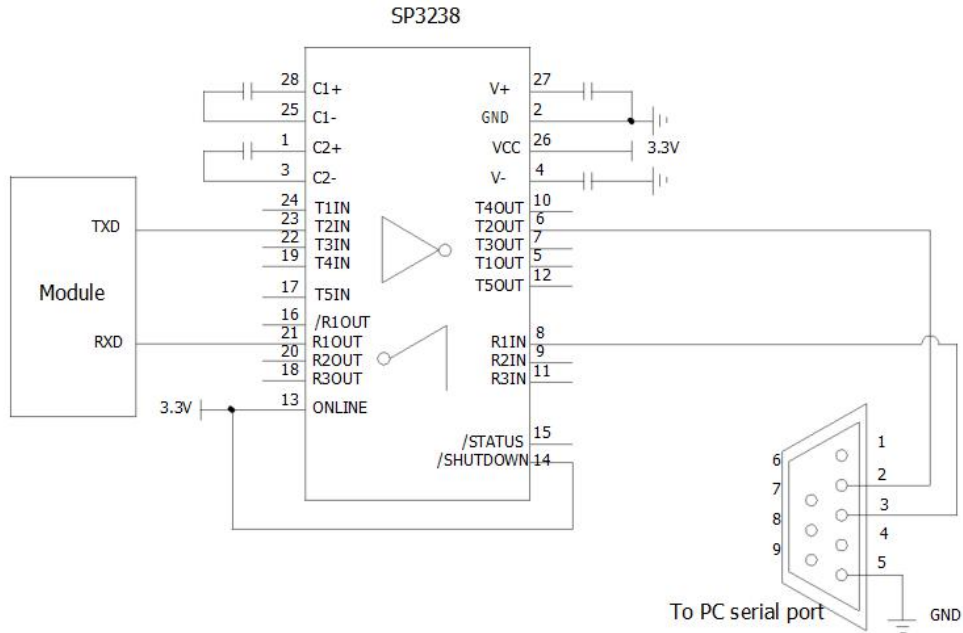

**Figure 7: RS-232 Level Shift Circuit**

### 2.5. PPS VS. NMEA

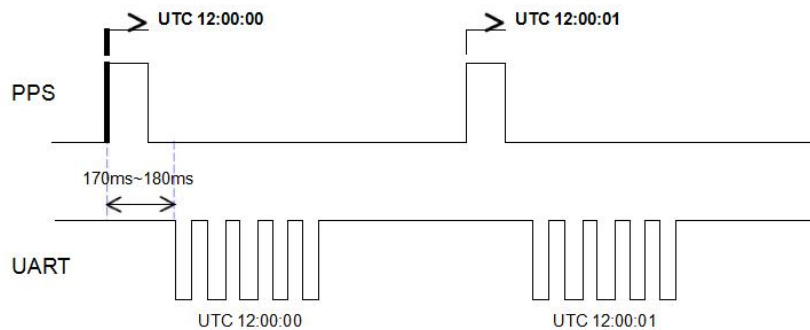

**Figure 8: PPS VS. NMEA Timing**

This feature only supports 1Hz NMEA output and baud rate at 14400~115200bps. At baud rate of 9600bps and 4800bps, it only supports RMC NMEA sentence. Because at low baud rate, per second transmission may exceed one second if there are many NMEA sentences output.

### 3 Antenna Interfaces

#### 3.1. PCB Design Guide

The GT-1110-TDBD GPS&Beidou receiver is designed for supporting the active antenna or passive antenna connected with pin RF\_IN. The gain of active antenna should be no less than 15dB. The maximum noise figure should be no more than 2.5dB and output impedance is at 50 Ohm.

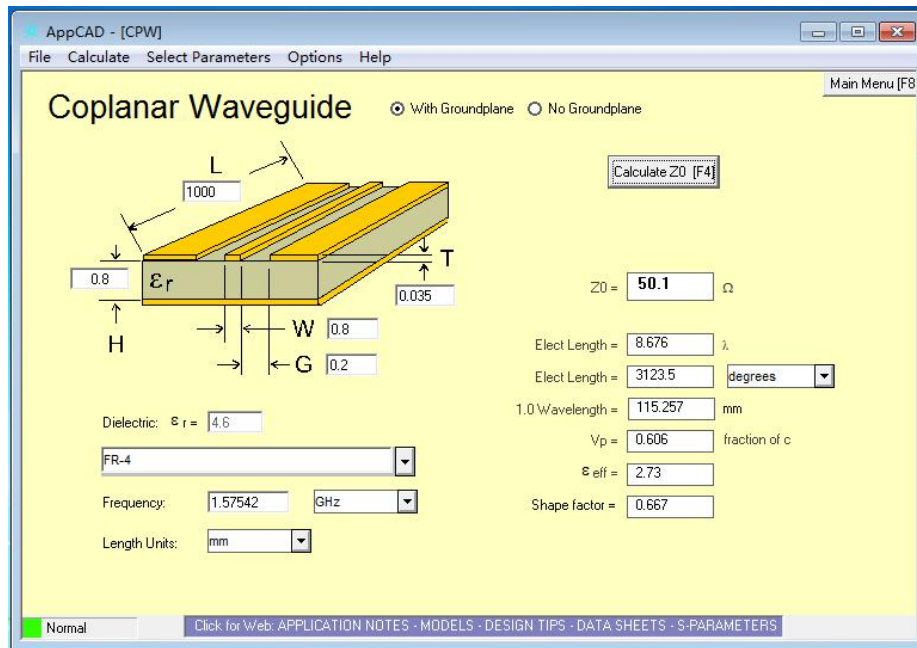

**Figure 9:** Antenna design requirements

#### 3.2. External Active Antenna

The following figure is a typical reference design with active antenna. In this mode, DC on the VDD\_3.3V pin is powered to power the external active antenna.

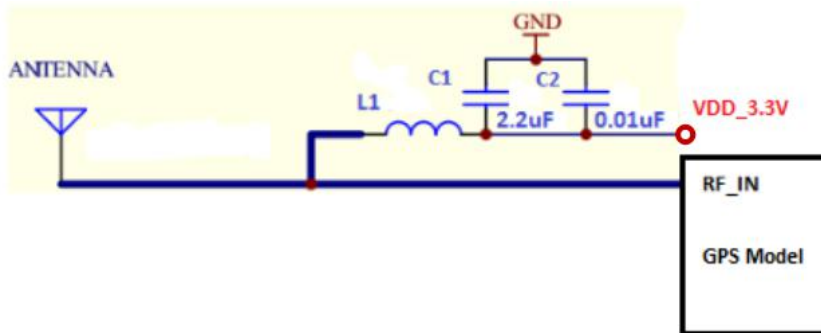

**Figure 10:** Reference Design for Active Antenna

C1, C2, L1 is used for power supply and filtering effect to the external active antenna, RF\_IN antenna to a circuit part (BOLD line) for high frequency microstrip line, PCB in the design of this part of the line to calculate the characteristic impedance of the high-frequency line according to the principle of high frequency wiring.

◇ Requirements: this section of the line in the 1575.42MHz frequency characteristic impedance requirement is 50 ohm.

**Table 2: The modules Antenna Specifications**

Parameter	Specification	
Antenna Type	Passive and active antenna	
ActiveAntenna Recommendations	Minimum gain	15 dB (to compensate signal loss in RF cable)
	Maximum gain	50 <sup>9</sup> dB / 30 <sup>10</sup> dB
	Maximum noise figure	1.5 dB

## 4 Electrical, Reliability and Radio Characteristics

### 4.1. Absolute Maximum Ratings

Absolute maximum ratings for power supply and voltage on digital pins of the module are listed in the following table.

**Table 3: Absolute Maximum Ratings**

values within the specified boundaries by using appropriate protection diodes.

Parameter	Min.	Max.	Unit
Power Supply Voltage (VCC)	-0.3	3.6	V
Backup Battery Voltage (VBAT)	-0.3	3.6	V
Input Voltage at Digital Pins	-0.3	3.6	V
Input Power at RF_IN		15	dBm
Storage Temperature	-45	125	°C

- ◇ Stressing the device beyond the “Absolute Maximum Ratings” may cause permanent damage. These are stress ratings only. The product is not protected against over voltage or reversed voltage. If necessary, voltage spikes exceeding the power supply voltage specification, given in table above, must be limited to values within the specified boundaries by using appropriate protection diodes.

## 4.2. Operating Conditions

**Table 4: Power Supply Ratings**

Parameter	Description	Conditions	Min.	Typ.	Max.	Unit
VCC	Supply voltage	Voltage must stay within the min/max values, including voltage drop, ripple, and spikes.	2.8	3.3	3.6	V
IVCCP	Peak supply current	VCC=3.3V			100	mA
VBAT	Backup voltage supply		1.8	3.3	3.6	V
TOPR	Normal operating temperature		-40	25	80	°C

- ◇ The figure IVCCP can be used to determine the maximum current capability of power supply.
- ◇ Operation beyond the "Operating Conditions" is not recommended and extended exposure beyond the "Operating Conditions" may affect the device’s reliability.

## 4.3. Current Consumption

The values for current consumption are shown in the following table.

**Table 5: Current Consumption**

Parameter	Conditions	Min.	Typ.	Max.	Unit
Ivcc @Acquisition	VCC=V BCKP=3.3V		25		mA
Ivcc @Tracking	VCC=VBAT=3.3V		20		mA
Ivcc @Standby	VCC=VBAT=3.3V		2.0		mA
IBCKP @Backup	VBAT=3.3V		20		uA

**The tracking current is tested in the following conditions:**

- ◇ In Cold Start, 10 minutes after First Fix.
- ◇ In Hot Start, 15 seconds after First Fix.

#### 4.4. Electrostatic Discharge

GT-1110-TDBD module is an ESD sensitive device. ESD protection precautions should still be emphasized. Proper ESD handling and packaging procedures must be applied throughout the processing, handling and operation of any application.

The ESD bearing capability of the module is listed in the following table. Note that you should add ESD components to module pins in particular applications.

**Table 6: ESD Endurance Table (Temperature : 25°C, Humidity: 45%)**

Pin	Contact Discharge	Air Discharge
RF_IN	±5KV	±10KV
VCC	±5KV	±10KV
UART	±3KV	±6KV
Others	±2KV	±4KV

## 5 Mechanical Dimensions

This chapter describes the mechanical dimensions of the module.

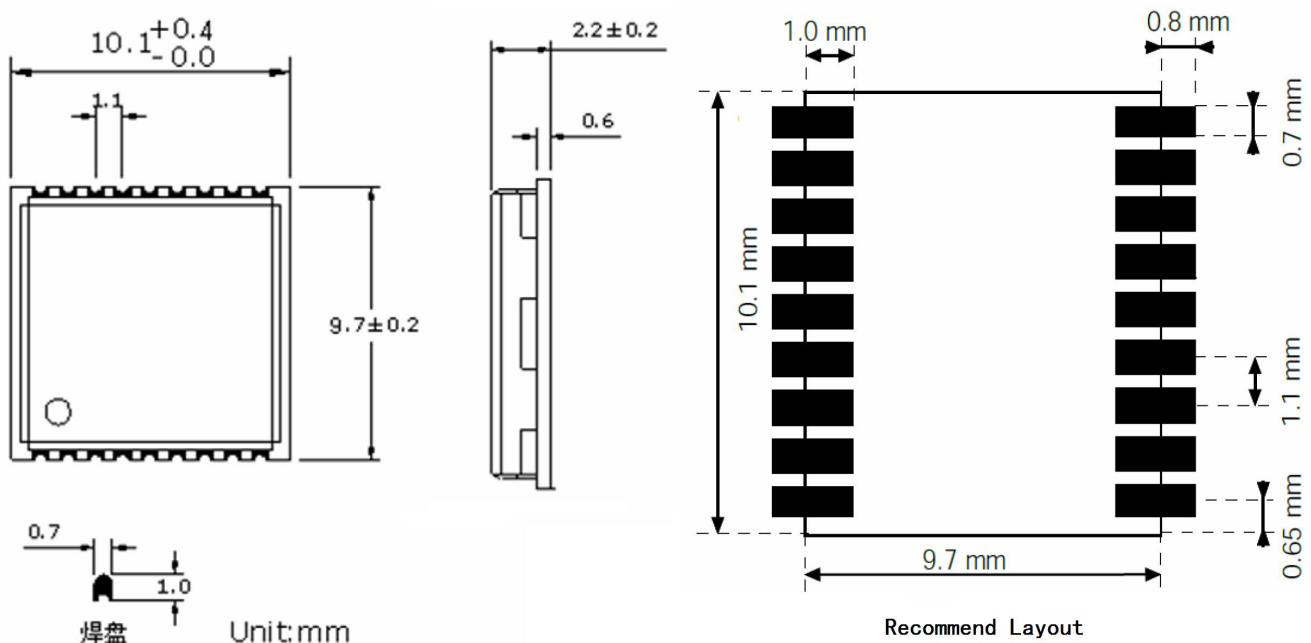

**Figure 10: Bottom View Dimensions**

## 6 Manufacturing, Packaging and Ordering Information

### 6.1. Assembly and Soldering

GT-1110-TDBD module is intended for SMT assembly and soldering in a Pb-free reflow process on the top side of the PCB. It is suggested that the minimum height of solder paste stencil is 100um to ensure sufficient solder volume. Pad openings of paste mask can be increased to ensure proper soldering and solder wetting over pads. It is suggested that the peak reflow temperature is 235~245° C (for SnAg3.0Cu0.5 alloy). The absolute maximum reflow temperature is 260° C. To avoid damage to the module when it is repeatedly heated, it is suggested that the module should be mounted after reflow soldering for the other side of PCB has been completed. Recommended reflow soldering thermal profile is shown below:

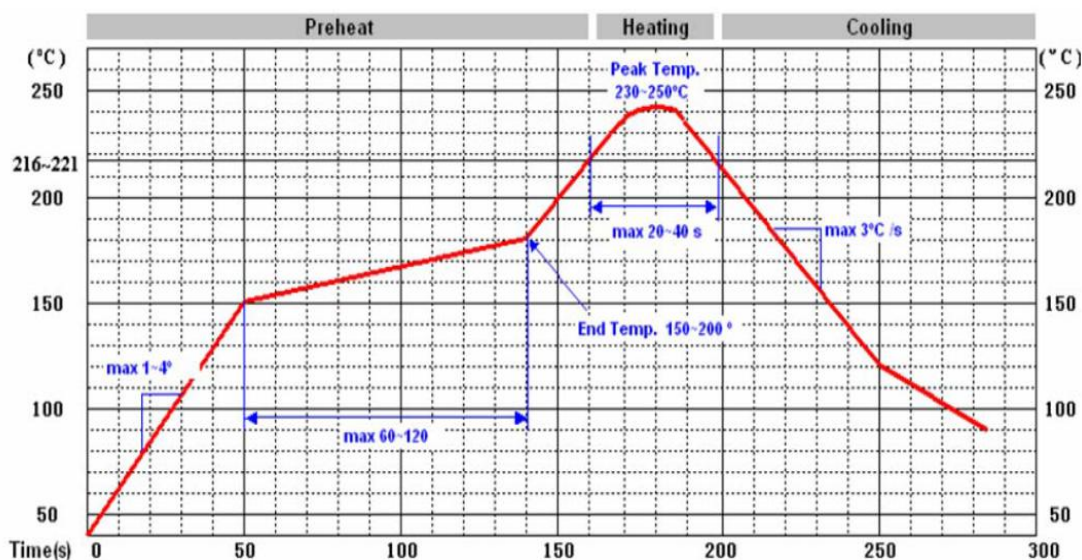

Figure 11: Recommended Reflow Soldering Thermal Profile

### 6.2. Moisture Sensitivity

GT-1110-TDBD module is sensitive to moisture. To prevent GT-1110-TDBD from permanent damage during reflow soldering, baking before reflow soldering is required in following cases:

- ◇ Humidity indicator card: One or more indicating spots are no longer blue.
- ◇ The seal is opened and the module is exposed to excessive humidity.

GT-1110-TDBD should be baked for 192 hours at temperature 40°C±5°C/-0°C and <5% RH in low-temperature containers, or 24 hours at temperature 125°C±5°C in high-temperature containers. Care should be taken that the plastic tape is not heat resistant. GT-1110-TDBD should be taken out from the tape before preheating; otherwise, the tape maybe damaged by high-temperature heating.

### 6.3. ESD Protection

GT-1110-TDBD module is sensitive to ESD and requires special precautions when handling. Particular care must be exercised when handling patch antenna, duo to the risk of electrostatic charges.

**6.4. Tape and Reel Packaging**

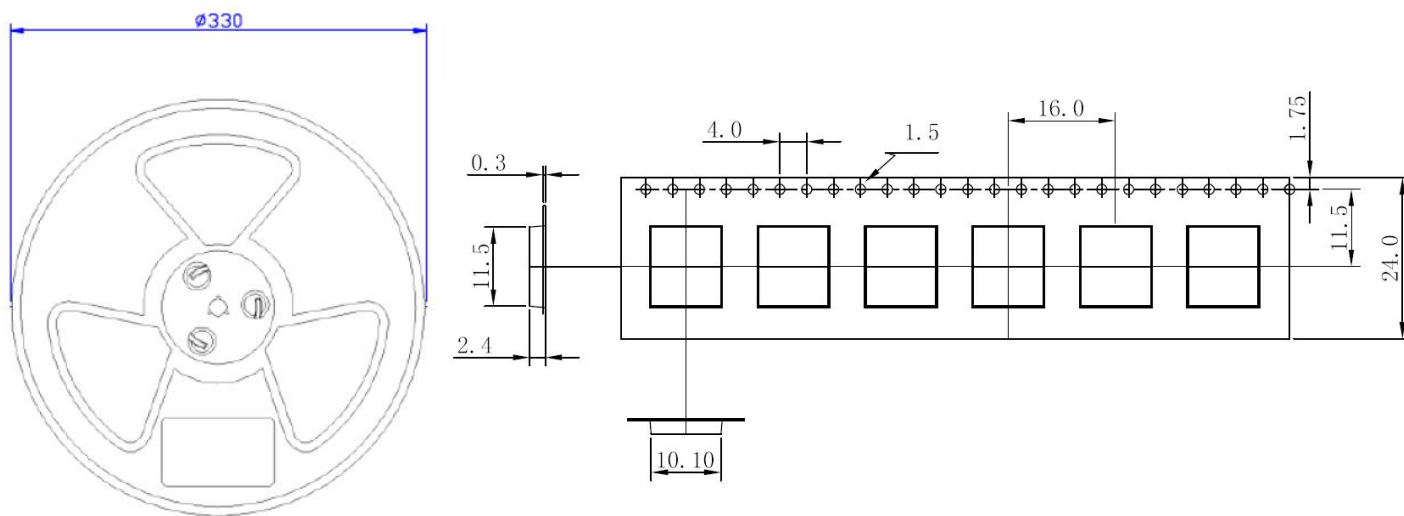

Unit: mm

Quantity per reel: 1000pcs

Length per reel: 16m

**Figure 12: Tape and Reel Specifications**



**Figure 13: Packaging physical Figure**

**Table 8: Reel Packaging**

Model Name	MOQ for MP	Minimum Package: 1000pcs
GT-1110-TDBD	1000pcs	Size: 365mm × 350mm × 53mm N.W: 0.87kg G.W: 1.05kg

## 7 Appendix References

**Table 9: Terms and Abbreviations**

Abbreviation	Description
AGNSS	Assisted Global navigation satellite system
DGPS	Differential GPS
ESD	Electrostatic Discharge
GPS	Global Positioning System
GNSS	Global Navigation Satellite System
GGA	GNSS Fix Data
GLL	Geographic Position – Latitude/Longitude
GLONASS	Global Navigation Satellite System
GSA	GNSS DOP and Active Satellites
GSV	GNSS Satellites in View
HDOP	Horizontal Dilution of Precision
I/O	Input/Output
Kbps	Kilo Bits Per Second
LNA	Low Noise Amplifier
MSAS	Multi-Functional Satellite Augmentation System
MOQ	Minimum Order Quantity
NMEA	National Marine Electronics Association
PDOP	Position Dilution of Precision
PPS	Pulse Per Second
PRN	Pseudo Random Noise Code
QZSS	Quasi-Zenith Satellite System
RHCP	Right Hand Circular Polarization
RMC	Recommended Minimum Specific GNSS Data
SBAS	Satellite-based Augmentation System
SAW	Surface Acoustic Wave
SPDT	Single-Pole Double-Throw
TTFF	Time To First Fix



UART	Universal Asynchronous Receiver & Transmitter
VDOP	Vertical Dilution of Precision
VTG	Course over Ground and Ground Speed, Horizontal Course and Horizontal Velocity
WAAS	Wide Area Augmentation System
Inom	Nominal Current
Imax	Maximum Load Current
Vmax	Maximum Voltage Value
Vnom	Nominal Voltage Value
Vmin	Minimum Voltage Value
VIHmax	Maximum Input High Level Voltage Value
VIHmin	Minimum Input High Level Voltage Value
VILmax	Maximum Input Low Level Voltage Value
VILmin	Minimum Input Low Level Voltage Value
VImax	Absolute Maximum Input Voltage Value
Vimin	Absolute Minimum Input Voltage Value
VOHmax	Maximum Output High Level Voltage Value
VOHmin	Minimum Output High Level Voltage Value
VOLmax	Maximum Output Low Level Voltage Value
VOLmin	Minimum Output Low Level Voltage Value

## 8 NMEA 0183 Protocol

The NMEA protocol is an ASCII-based protocol, Records start with a \$ and with carriage return/line feed. GPS&Beidou specific messages all start with \$GPxxx/\$BDxxx where \$GNxxx is a three-letter identifier of the message data that follows. NMEA messages have a check sum, which allows detection of corrupted data transfers.

This module supports three modes of instruction configuration, each mode corresponding to the NMEA data such as *Table 10*.

**Table 10: Each mode corresponds to the NMEA data**

Pattern	Instructions	NMEA Out Put
GPS		GPRMC.GPGGA.GPGSV.GPGSA
Beidou		BDRMC.BDGGA.BDGSV.BDGSA
GPS& Beidou		GNRMC.GNGGA.GPGSV.BDGSV. GNGSA.GNGSA

◇ The Gotop GT-1110-TDBD Initialization location mode for GPS&Beidou dual mode,  
Output data: \$GNGGA. \$GNRMC. \$GNGSA. \$GNGSA. \$BDGSV. \$GPGSV

### 8.1 GGA-Global Positioning System Fixed Data

\$xxGGA,062411.00,2238.52974,N,11401.96571,E,1,07,2.05,82.5,M,-2.2,M,,\*6F

**Table 11: GGA Data Format**

Name	Example	Units	Description
Message ID	\$xxGGA		GGA protocol header
UTC Position	062411.00		hhmmss.ss
Latitude	2238.52974		ddmm.mmmmm
N/S indicator	N		N=north or S=south
Longitude	11401.96571		dddmm.mmmmm
E/W Indicator	E		E=east or W=west
Position Fix Indicator	1		See Table 11-1
Satellites Used	07		Range 0 to 12
HDOP	2.05		Horizontal Dilution of Precision
MSL Altitude	82.5	meters	
Units	M	meters	
Geoids Separation	-2.2	meters	
Units	M	meters	
Age of Diff.Corr.		second	Null fields when DGPS is not Used
Diff.Ref.Station ID			0000~1023
Checksum	*6F		
<CR> <LF>			End of message termination

**Table 11-1: Position Fix Indicators**

Value	Description
0	Fix not available or invalid
1	GPS&BD SPS Mode, fix valid
2	Differential GPS, SPS Mode, fix valid
3	GPS&BD PPS Mode, fix valid

### 8.2 GSA-GNSS DOP and Active Satellites

\$xxGSA,A,3,06,30,02,,,,,,,,,2.95,2.05,2.12,1\*0E

\$xxGSA,A,3,01,02,04,05,,,,,,,,,2.95,2.05,2.12,4\*0E

**Table 12: GSA Data Format**

Name	Example	Units	Description
Message	\$xxGSA		GSA protocol header
Mode 1	A		See Table 12-2
Mode 2	3		See Table 12-1
Satellite Used	07		Sv on Channel 1
Satellite Used	02		Sv on Channel 2
...	...		...
Satellite Used			Sv on Channel 66
PDOP	2.95		Position Dilution of Precision
HDOP	2.05		Horizontal Dilution of Precision
VDOP	2.12		Vertical Dilution of Precision
GNSS System Identifier	1		See Table 12-3
Check sum	*0E		
<CR> <LF>			End of message termination

**Table 12-1: Mode 1**

Value	Description
1	Fix not available
2	2D
3	3D

**Table 12-2: Mode 2**

Value	Description
M	Manual-forced to operate in 2D or 3D mode
A	Automatic-allowed to automatically switch 2D/3D

**Table 12-3: Mode 3**

Value	Description
1	GPS positioning system
2	GLONASS positioning system
3	Galileo positioning system
4	Beidou positioning system

### 8.3 GSV-GNSS Satellites in View

\$xxGSV,2,1,06,02,06,240,35,06,42,255,43,22,,,34,30,24,198,45,0\*52

\$xxGSV,2,2,06,42,51,128,36,50,46,123,38,0\*63

**Table 13: GGA Data Format**

Name	Example	Units	Description
Message ID	\$xxGSV		GSV protocol header
Number of Message	2		Range 1 to 3
Message Number	1		Range 1 to 3
Satellites in View	06		
Satellite ID	02		Channel 1(Range 1 to 66)
Elevation	06	degrees	Channel 1(Maximum 90)
Azinmuth	240	degrees	Channel 1(True, Range 0 to 359)
SNR(C/NO)	35	dBHz	Range 0 to 99,null when not tracking
...			...
Satellite ID	06		Channel 4(Range 1 to 66)
Elevation	42	degrees	Channel 4(Maximum 90)
Azimuth	255	degrees	Channel 4(True, Range 0 to 359)
SNR(C/NO)	43	dBHz	Range 0 to 99, null when not tracking
Checksum	*52		
<CR> <LF>			End of message termination

Depending on the number of satellites tracked multiple messages of GSV data may be required.

### 8.4 RMC-Recommended Minimum Specific GNSS Data

Table 5 contains the values of the following example:

\$xxRMC, 161229.487, A, 3723.2475, N, 12158.3416, W, 0.13,309.62, 120598,, \*10

\$xxRMC,062411.00,A,2238.52974,N,11401.96571,E,0.099,,280716,,,A,V\*11

**Table 14: RMC Data Format**

Name	Example	Units	Description
Message ID	\$xxRMC		RMC protocol header
UTS Position	062411.00		hhmmss.ss
Status	A		A=data valid or V=data not valid

Latitude	2238.52974		ddmm.mmmmm
N/S Indicator	N		N=north or S=south
Longitude	11401.96571		dddmm.mmmmm
E/W Indicator	E		E=east or W=west
Speed Over Ground	0.099	Knots	
Course Over		Degrees	True
Date	280716		Dummy
True course of the earth		Degrees	East offset (E), subtract from true heading
True course of the earth		Degrees	West to offset (W), and true course addition.
Mode indication	A		See Table 14-1
Navigation state	V		See Table 14-2
Checksum	*11		
<CR> <LF>			End of message termination

**Table 14-1: Mode 1**

Value	Description
A	Autonomous Mode
D	Difference mode
E	Estimate (dead reckoning) mode
M	Manual input mode
S	Simulator mode
N	Null data

**Table 14-2: Mode 2**

Value	Description
S	Safe: mode corresponds to the level of accuracy, integrity is available and meet the requirements of actual navigation mode and the computation time of the effective position of traditional plane is less than 1s, for high speed aircraft is less than 0.5s
C	Caution: Integrity is not available.
U	Unsafe: navigation mode selection accuracy level, or good usability, but beyond the actual navigation mode, or new effective position can't be within the specified time calculation (1s for traditional aircraft, high-speed aircraft is 0.5s).
V	The navigation status is not valid and the device cannot provide navigation status indication.

**©Copyright 2016 Gotop Technology Co., Ltd. All Right Reserved**

**The information contained herein is subject to change without notice.**

**Gotop Technology Co. , LTD**

Add:Room 603 Zhantao Technology Building,Minzhi Road,Xinniu Communnity,Minzhi Street, Baoan District, ShenZhen City China.

Phone: 86-755-23804156

fax: 86-755-23804155

N 22° 32' 17", E 114° 07' 07"

<http://www.gotop-zzu.com>

Not to be reproduced in whole or part for any purpose without written permission of Gotop Technology Inc ('Gotop'). Information provided by Gotop is believed to be accurate and reliable. These materials are provided by Gotop as a service to its customers and may be used for informational purposes only. Gotop assumes no responsibility for errors or omissions in these materials, nor for its use. Gotop reserves the right to change specification at any time without notice.

These materials are provides 'as is' without warranty of any kind, either expressed or implied, relating to sale and/or use of Gotop products including liability or warranties relating to fitness for a particular purpose, consequential or incidental damages, merchantability, or infringement of any patent, copyright or other intellectual property right. Gotop further does not warrant the accuracy or completeness of the information, text, graphics or other items contained within these materials. Gotop shall not be liable for any special, indirect, incidental, or consequential damages, including without limitation, lost revenues or lost profits, which may result from the use of these materials.

Gotop products are not intended for use in medical, life-support devices, or applications involving potential risk of death, personal injury, or severe property damage in case of failure of the product.