

## General Description

The Gotop GAM-3026-MTGN is a complete GPS&GLONASS engine module that features super sensitivity, ultra low power and small form factor. The GPS&GLONASS signal is applied to the antenna input of module, and a complete serial data message with position, velocity and time information is presented at the serial interface with NMEA protocol or custom protocol.

Its  $-165\text{dBm}$  tracking sensitivity extends positioning coverage into place like urban canyons and dense foliage environment where the GPS&GLONASS was not possible before. The small form factor and low power consumption make the module easy to integrate into portable device like PNDs, mobile phones, cameras and vehicle navigation systems.

## Applications

- LBS (Location Based Service)
- PND (Portable Navigation Device)
- Vehicle navigation system
- Mobile phone



**Figure1: GAM-3026-MTGN Top View**

## Features

- Build on high performance, low-power MediaTek MT3333 chip set
- Ultra high Track sensitivity:  $-165\text{dBm}$
- Extremely fast TTFB at low signal level
- Built in high gain LNA
- Low power consumption: Max  $45\text{mA}@3.3\text{V}$
- NMEA-0183 compliant protocol or custom protocol
- Operating voltage:  $3.0\text{V}$  to  $5.0\text{V}$
- Operating temperature range:  $-40$  to  $85^\circ\text{C}$
- Patch Antenna Size:  $25 \times 25 \times 4\text{mm}$
- Module Size:  $30 \times 26 \times 8.0\text{mm}$
- Communication type: UART/TTL
- RoHS compliant (Lead-free)

# 1 Description

## 1.1. Key Features

Parameter	Specification
Power Supply	<ul style="list-style-type: none"> <li>Supply voltage: 3.0V~5.0V Typical: 3.3V</li> </ul>
Power Consumption	<ul style="list-style-type: none"> <li>Acquisition: 45mA @VCC=VBAT=3.3V</li> <li>Tracking: 40mA @VCC=VBAT=3.3V</li> <li>Standby: 2.0mA @VCC=VBAT=3.3V</li> <li>Backup: 20uA @VBAT=3.3V</li> </ul>
Receiver Type	<ul style="list-style-type: none"> <li>Code 66 search channels, 22 synchronous tracking channels</li> <li>GPS&amp;QZSS L1 1575.42MHz C/A , GLONASS L1OF 1602MHz</li> <li>SBAS: WAAS, EGNOS, MSAS, GAGAN</li> </ul>
Sensitivity	<ul style="list-style-type: none"> <li>Tracking: -165dBm</li> <li>Re-acquisition: -156dBm</li> <li>Acquisition: -148dBm</li> </ul>
TTF (EASY enabled)	<ul style="list-style-type: none"> <li>Cold start: 15s typ @-130dBm</li> <li>Warm start: 5s typ @-130dBm</li> <li>Hot start : 1s typ @-130dBm</li> </ul>
TTF (EASY disabled)	<ul style="list-style-type: none"> <li>Cold start(Autonomous): 35s typ @-130dBm</li> <li>Warm start (Autonomous): 30s typ @-130dBm</li> <li>Hot start (Autonomous): 1s typ @-130dBm</li> </ul>
Horizontal Position Accuracy (Autonomous)	<ul style="list-style-type: none"> <li>&lt;2.5m CEP @-130 dBm</li> </ul>
Max Update Rate	<ul style="list-style-type: none"> <li>Up to 10Hz,1Hz by fault</li> </ul>
Accuracy of 1PPS Signal	<ul style="list-style-type: none"> <li>not enabled</li> </ul>
Acceleration Accuracy	<ul style="list-style-type: none"> <li>Without aid: 0.1m/s<sup>2</sup></li> </ul>
Dynamic Performance	<ul style="list-style-type: none"> <li>Maximum altitude: 18,000m</li> <li>Maximum velocity: 515m/s</li> <li>Acceleration: 4G</li> </ul>
UART Port	<ul style="list-style-type: none"> <li>UART Port: TXD and RXD</li> <li>Supports baud rate from 4800bps to 115200bps, 9600bps by default</li> <li>UART port is used for NMEA output, MTK proprietary commands input and firmware upgrade</li> </ul>
Temperature Range	<ul style="list-style-type: none"> <li>Normal operation: -40°C ~ +85°C</li> <li>Storage temperature: -45°C ~ +125°C</li> </ul>
Physical Characteristics	<ul style="list-style-type: none"> <li>Size: 30±0.20 ×26±0.20 ×8.0±0.20mm</li> <li>Weight: Approx. 11.9g</li> </ul>

### 1.2 Power Supply

Regulated power for the GAM-3026-MTGN is required. The VCC Pin Need a stable DC voltage supply. Power supply ripple must be less than 30mV. The input voltage Vcc should be 3.0V~5.0V, Recommended power supply voltage is 3.3V . maximum current is 45mA. Suitable decoupling must be provided by external decoupling circuitry.

### 1.3 UART Ports

The module supports two full duplex serial channels UART. All serial connections are at 3V CMOS logic levels, if need different voltage levels, use appropriate level shifters. The baud rate of both serial ports are fully programmable, the data format is however fixed: X, N, 8, 1, i.e. X baud rate, no parity, eight data bits and one stop bit, no other data formats are supported, LSB is sent first. The modules default baud rate is set up 9600bps, however, the user can change the default baud rate to any value from 4800 bps to 115kbps. UART port can be used for firmware upgrade, NMEA output and PMTK proprietary commands input.

## 2 Application

The module is equipped with a 5-pin pad that connects to your application platform. The GAM-3026-MTGN module It consists of a MediaTek MT3333 single chip GNSS IC which includes the RF part and Baseband part, a patch antenna, a LNA, a SAW filter, a TCXO, a crystal oscillator, Also comes with a 0.22F crystal capacitor ,can backup satellite ephemeris about 2 hour.

### 2.1. Pin Assignment

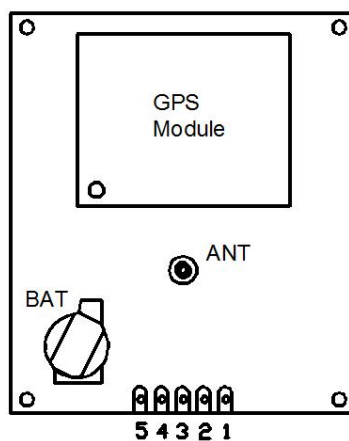

**Figure 2:** Pin Assignment

**Table 2: CON Pin Description**

Pin No.	Pin name	I/O	Description	Remark
1	GND	G	Ground	
2	VCC	I	Module Power Supply	
3	VBAT	I	RTC Battery Input	
4	RXD	I	UART Serial Data Input	
5	TXD	O	UART Serial Data output	

## 2.2 Mechanical Dimensions

This chapter describes the mechanical dimensions of the GAM-3026-MTGN module. Size unit (mm)

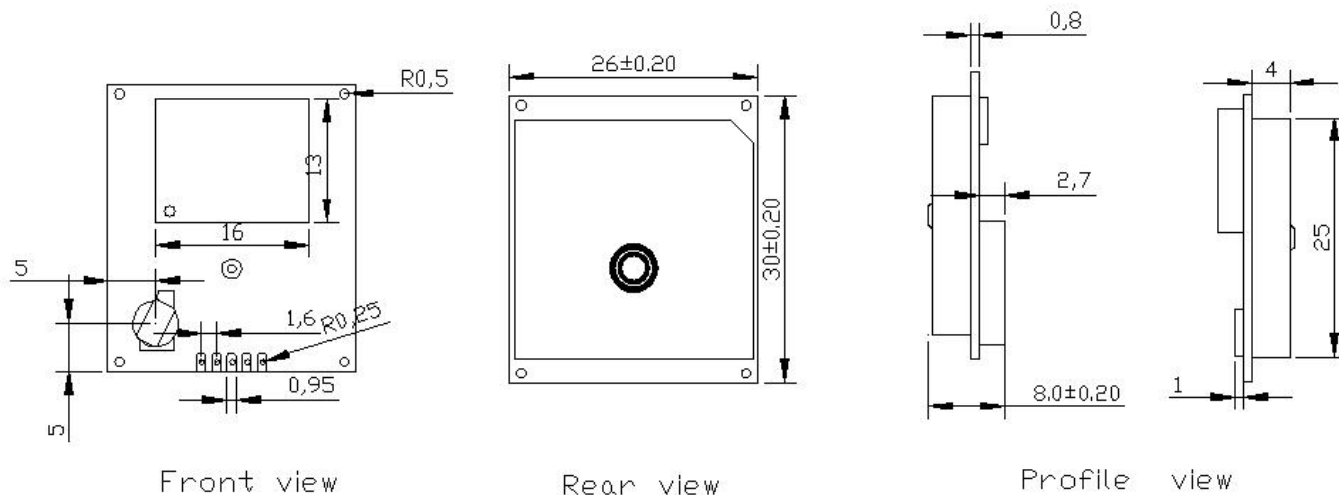

**Figure 3: Specification size chart**

### 3 NMEA 0183 Protocol

The NMEA protocol is an ASCII-based protocol, Records start with a \$ and with carriage return/line feed. GPS&GLONASS specific messages all start with \$GPxxx/\$GLxxx where \$GNxxx is a three-letter identifier of the message data that follows. NMEA messages have a check sum, which allows detection of corrupted data transfers.

#### 3.1 Location mode configuration instructions

Single system or dual system positioning mode can be selected through the configuration instructions, configuration instructions such as *Table 1*.

**Table 1: Instruction configuration instructions**

Pattern	Instructions	NMEA Out Put
GPS	\$PMTK353,1,0*36	GPRMC.GPGGA.GPGSV.GPGSA.GPGLL.GPVTG
GLONASS	\$PMTK353,0,1*36	GLRMC.GLGGA.GLGSV.GLGSA.GLGLL.GLVTG
GPS&GLONASS	\$PMTK353,1,1*37	GNRMC.GNGGA.GPGSV.GLGSV.GPGSA.GLGSA. GNGLL.GNVTG

- ◇ The Gotop GAM-3026-MTGN initialization location mode for GPS&GLONASS dual mode.  
Output data: \$GNRMC. \$GNGGA. \$GPGSV. \$GLGSV. \$GPGSA. \$GLGSA.\$GNGLL. \$GNVTG

#### 3.2 NMEA-0183 data Detailed field

##### 3.2.1 GGA-Global Positioning System Fixed Data

\$xxGGA, 161229.487,3723.2475,N, 12158.3416,W, 1,07,1.0,9.0,M.0000\*18

**Table 2: GGA Data Format**

Name	Example	Units	Description
Message ID	\$xxGGA		GGA protocol header
UTC Position	161229.487		hhmmss.sss
Latitude	3723.2457		ddmm.mmmm
N/S indicator	N		N=north or S=south
Longitude	12158.3416		dddmm.mmmm
E/W Indicator	W		E=east or W=west
Position Fix Indicator	1		See Table 2-1
Satellites Used	07		Range 0 to 12
HDOP	1.0		Horizontal Dilution of Precision

MSL Altitude	9.0	meters	
Units	M	meters	
Geoids Separation		meters	
Units	M	meters	
Age of Diff.Corr.		second	Null fields when DGPS is not Used
Diff.Ref.Station ID	0000		
Check sum	*18		
<CR> <LF>			End of message termination

**Table 2-1: Position Fix Indicators**

Value	Description
0	Fix not available or invalid
1	GPS&GLONASS SPS Mode, fix valid
2	Differential GPS&GLONASS, SPS Mode, fix valid
3	GPS&GLONASS PPS Mode, fix valid

### 3.2.2 GLL-Geographic Position - Latitude/Longitude

\$xxGLL , 3723.2475, N,12158.3416, W,161229.487, A\*2C.

**Table 3: GLL Data Format**

Name	Example	Units	Description
Message ID	\$xxGLL		GLL protocol header
Latitude	3723.2475		ddmm.mmmm
N/S Indicator	N		N=north or S=south
Longitude	12158.3416		dddmm.mmmm
E/W Indicator	W		E=east or W=west
UTC Position	161229.487		hhmmss.sss
Status	A		A=data valid or V=data not valid
Check sum	*2C		
<CR> <LF>			End of message termination

### 3.2.3 GSA-GNSS DOP and Active Satellites

\$xxGSA , A, 3, 07, 02, 26,27, 09, 04,15, , , , , 1.8,1.0,1.5\*33.

**Table 4: GSA Data Format**

Name	Example	Units	Description
Message	\$xxGSA		GSA protocol header
Mode 1	A		See Table 4-2
Mode 2	3		See Table 4-1
Satellite Used	07		Sv on Channel 1
Satellite Used	02		Sv on Channel 2
...	...		...
Satellite Used			Sv on Channel 66
PDOP	1.8		Position Dilution of Precision
HDOP	1.0		Horizontal Dilution of Precision
VDOP	1.5		Vertical Dilution of Precision
Check sum	*33		
<CR> <LF>			End of message termination

**Table 4-1: Mode 1**

Value	Description
1	Fix not available
2	2D
3	3D

**Table 4-2: Mode 2**

Value	Description
M	Manual-forced to operate in 2D or 3D mode
A	Automatic-allowed to automatically switch 2D/3D

### 3.2.4 GSV-GNSS Satellites in View

\$xxGSV , 2, 1, 07, 07, 79,048, 42, 02, 51,062, 43, 26, 36,256, 42, 27, 27, 138,42\*71

\$xxGSV , 2, 2, 07, 09, 23,313, 42, 04, 19, 159, 41, 15,12,041, 42\*41.

**Table 5: GSV Data Format**

Name	Example	Units	Description
Message ID	\$xxGSV		GSV protocol header
Number of Message	2		Range 1 to 3
Message Number	1		Range 1 to 3

Satellites in View	07		
Satellite ID	07		Channel 1(Range 1 to 66)
Elevation	79	degrees	Channel 1(Maximum 90)
Azinmuth	048	degrees	Channel 1(True, Range 0 to 359)
SNR(C/NO)	42	dBHz	Range 0 to 99,null when not tracking
...			...
Satellite ID	27		Channel 4(Range 1 to 66)
Elevation	27	degrees	Channel 4(Maximum 90)
Azimuth	138	degrees	Channel 4(True, Range 0 to 359)
SNR(C/NO)	42	dBHz	Range 0 to 99, null when not tracking
Check sum	*71		
<CR> <LF>			End of message termination

✧ Depending on the number of satellites tracked multiple messages of GSV data may be required.

### 3.2.5 RMC-Recommended Minimum Specific GNSS Data

\$xxRMC, 161229.487, A, 3723.2475, N, 12158.3416, W, 0.13,309.62, 120598,, \*10

**Table 6: RMC Data Format**

Name	Example	Units	Description
Message ID	\$xxRMC		RMC protocol header
UTS Position	161229.487		hhmmss.sss
Status	A		A=data valid or V=data not valid
Latitude	3723.2475		ddmm.mmmm
N/S Indicator	N		N=north or S=south
Longitude	12158.3416		dddmm.mmmm
E/W Indicator	W		E=east or W=west
Speed Over Ground	0.13	Knots	
Course Over	309.62	Degrees	True
Ground			
Date	120598		Dummy
Magnetic variation		Degrees	E=east or W=west
Check sum	*10		
<CR> <LF>			End of message termination



### 3.2.6 VTG-Course Over Ground and Ground Speed

\$xxVTG, 309.62, T, M, 0.13, N, 0.2, K\*6E

**Table 17: VTG Data Format**

Name	Example	Units	Description
Message ID	\$xxVTG		VTG protocol header
Course	309.62	Degrees	Measured heading
Reference	T		True
Course		Degrees	Measured heading
Reference	M		Magnetic
Speed	0.13	Knots	Measured horizontal speed
Units	N		Knots
Speed	0.2	Km/hr	Measured horizontal speed
Units	K		Kilometer per hour
Check sum	*6E		
<CR> <LF>			End of message termination

**©Copyright 2016 Gotop Technology Co., Ltd. All Right Reserved**

**The information contained herein is subject to change without notice.**

**Gotop Technology Co. , LTD**

Add:Room 603 Zhantao Technology Building,Minzhi Road,Xinniu Communnity,Minzhi Street, Baoan District, ShenZhen City China.

Phone: 86-755-23804156

fax: 86-755-23804155

N 22° 32' 17", E 114° 07' 07"

<http://www.gotop-zzu.com>

Not to be reproduced in whole or part for any purpose without written permission of Gotop Technology Inc ('Gotop'). Information provided by Gotop is believed to be accurate and reliable. These materials are provided by Gotop as a service to its customers and may be used for informational purposes only. Gotop assumes no responsibility for errors or omissions in these materials, nor for its use. Gotop reserves the right to change specification at any time without notice.

These materials are provides 'as is' without warranty of any kind, either expressed or implied, relating to sale and/or use of Gotop products including liability or warranties relating to fitness for a particular purpose, consequential or incidental damages, merchantability, or infringement of any patent, copyright or other intellectual property right. Gotop further does not warrant the accuracy or completeness of the information, text, graphics or other items contained within these materials. Gotop shall not be liable for any special, indirect, incidental, or consequential damages, including without limitation, lost revenues or lost profits, which may result from the use of these materials.

Gotop products are not intended for use in medical, life-support devices, or applications involving potential risk of death, personal injury, or severe property damage in case of failure of the product.